

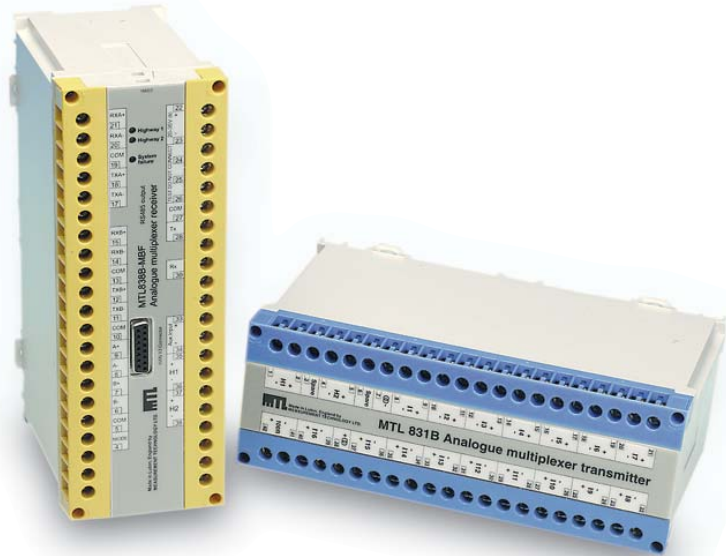

Cuts installation and
cable costs for all IS
hazardous-area circuits

MTL830 SERIES



- ◆ Reduce the cost of installing hazardous-area cabling
- ◆ Save installation time, space and weight
- ◆ Highlight problems quickly with status reporting systems
- ◆ Protect the process with sensor failure detection and safety drives
- ◆ Connect directly to host systems through serial-data outputs
- ◆ Analogue inputs to controllers with Modbus® communications
- ◆ Redundant data highways

MTL830 Series multiplexers with Modbus® outputs provide a cost-effective alternative to single-loop isolation. The cost of installed wiring is reduced by up to 50% by communicating the input of multiple hazardous-area sensors over dual-redundant data highways. Further savings are achieved by reducing the number of inputs to the host, cabinet space and weight.

A multiplexer transmitter, mounted in the hazardous area, caters for thermocouple, RTD and mV analogue inputs. A compatible safe-area receiver provides serial Modbus® outputs for feeding to host PLC, PC or DCS controllers.

Dual-redundant data highways between the transmitter and the receiver allow continuous normal operation with only one highway connected. The highway cable, a simple twisted pair or a pair of wires within an IS multi-core cable, carries both power and data, over distances up to 2km. If the multiplexer transmitter is located in the hazardous area, each data highway must be protected by an MTL3052 digital isolator.

Multiplexer systems can communicate the status of up to 32 inputs, reducing the number of hazardous area wiring pairs from 32 to two.

Reduce costs by eliminating long runs of expensive thermocouple compensation cable from the hazardous to the safe area. Also, if 3- or 4-wire RTDs are used, costs are reduced by terminating each RTD at the transmitter or its enclosure.

Dual redundant highways increase system reliability. Failure detectors and safety drives protect against the consequences of sensor failure, while built-in systems report failures to the host controller.

Accessories include steel and stainless-steel enclosures, earth-leakage detectors and a PC-based configuration software package.

For more information see AN9010, 'A user's guide to multiplexers' and TP1098, 'Cut the cost of intrinsic safety – by multiplexing!'



EUROPE (EMEA)
AMERICAS
ASIA PACIFIC
E-mail: enquiry@mtl-inst.com Web site: www.mtl-inst.com

Tel: +44 (0)1582 723633
Tel: +1 281 571 8065
Tel: +65 6 487 7887

Fax: +44 (0)1582 422283
Fax: +1 281 571 8069
Fax: +65 6 487 7997

MTL831B MULTIPLEXER TRANSMITTER



MTL831B multiplexer transmitters are normally sited in the hazardous area. They are connected to sensors in the field and communicate these inputs to the safe area via single-pair data highways. The data highways support communication between the safe and hazardous areas, and also provide power to the transmitters – no additional field power is required.

The MTL831B would typically be mounted close to the field instruments in an enclosure such as the ENC8 or ENC83 (see 'MTL800 Series Enclosures').

MTL831B ANALOGUE INPUT TRANSMITTER

Monitors inputs from up to 16 THC or millivolt sources (max $\pm 60\text{mV}$) or up to 15 2-, 3- or 4-wire RTDs within a hazardous area.

- ◆ Intrinsically safe; Zone 0 location
- ◆ Communication and power pass over twin data highways
- ◆ Powered by the data highway
- ◆ Thermocouples and RTDs may be mixed on one transmitter

MULTI-DROPPING TWO MTL831BS

Two MTL831B multiplexer transmitters can share the same single-pair highway to a single safe-area isolator/receiver combination, providing up to 32 multiplexed inputs.

DATA HIGHWAY CABLING

Cabling with low capacitance and resistance is recommended to achieve greater distances between transmitters and receivers. See cable parameters in 'Basic Specifications' for specific requirements, and contact MTL for latest cable recommendations. The system is designed to use both data highways, although it can be used with only one data highway in place. However, use of a single highway will increase response time.

Data highway lengths of up to 2km in hazardous areas and 3km in safe areas have been achieved.

ENCLOSURES

A range of steel and stainless steel enclosures is available for mounting MTL831B units in the field (see 'MTL800 Series Enclosures'). ENC8 and ENC8SS (stainless steel) enclosures provide protection for a single MTL831B. The enclosures are dust-tight and waterproof to IP67.

When using 4-wire RTDs, ENC83 and ENC83SS (stainless steel) enclosures provide additional terminals to accommodate the third and fourth RTD wires, which are not connected to the MTL831B itself.

MTL838B-MBF RECEIVERS



MTL838B-MBF receivers translate the information transmitted from the MTL831B via the data highway. The MTL838B-MBF provides a Modbus[®] serial-data output representation of the inputs together with status information.

MTL838B-MBF MODBUS[®] ANALOGUE RECEIVER

Translates data received from the MTL831B in the hazardous area and makes it available as twin RS485 Modbus[®] serial data outputs. The MTL838B-MBF is configured by personal computer for thermocouple and RTD type, safety drive, high and low alarm and any other operational parameters.

MTL3052 DATA HIGHWAY ISOLATOR

An MTL3052 isolator is required for each data highway, when the transmitter is located in a hazardous area. It is not required for safe-area applications.

MULTI-DROPPING MODBUS[®] RECEIVERS

Up to 31 Modbus receivers can be multi-dropped on a single RS485 link to the host system. Modbus[®] receivers can be controlled by any suitable Modbus[®] master. The receivers may be used with other Modbus[®] slaves on the same RS485 link.



MTL830 SERIES MULTIPLEXER SYSTEM DIAGRAM

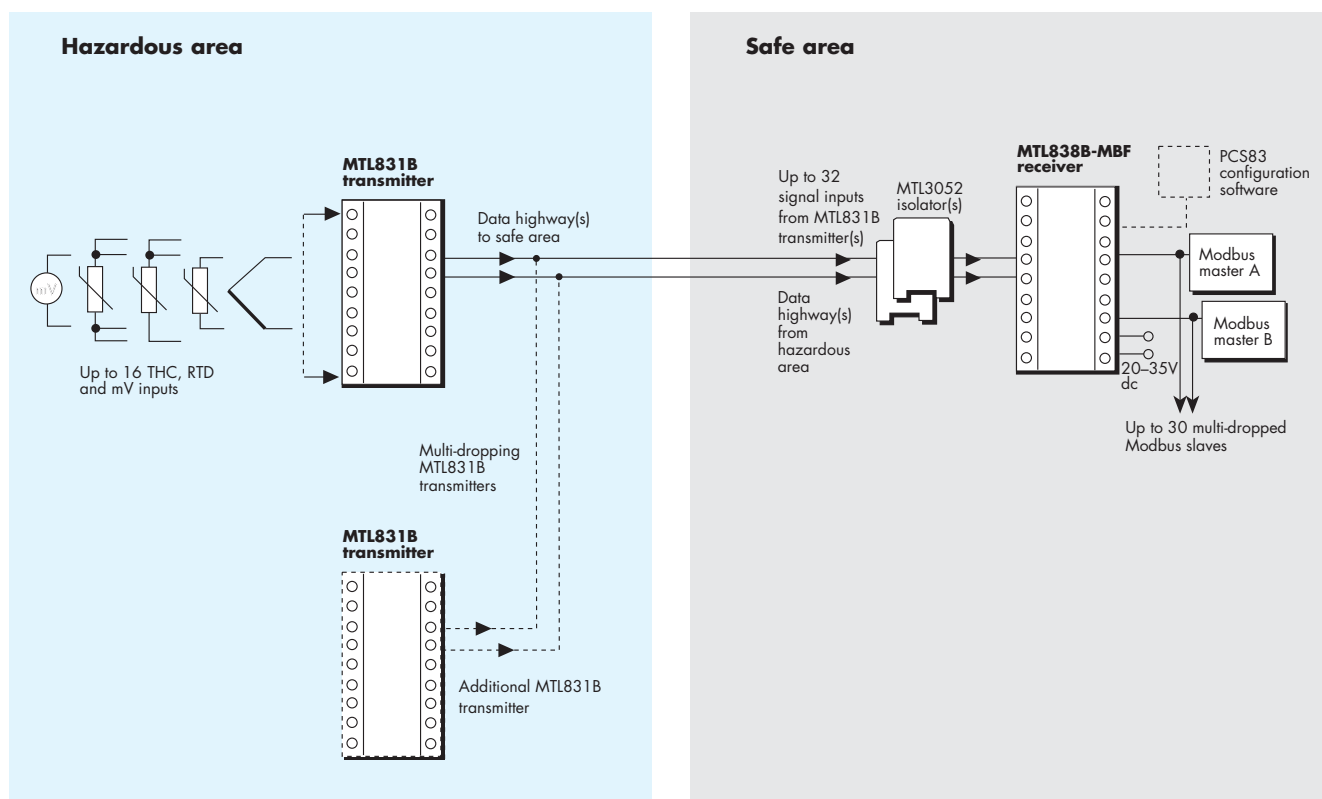

EUROPE (EMEA)
AMERICAS
ASIA PACIFIC
E-mail: enquiry@mtl-inst.com

Tel: +44 (0)1582 723633
Tel: +1 281 571 8065
Tel: +65 6 487 7887

Fax: +44 (0)1582 422283
Fax: +1 281 571 8069
Fax: +65 6 487 7997

Web site: www.mtl-inst.com

MTL831B

TRANSMITTERS

BASIC SPECIFICATIONS

(see also 'Common specification')

Number of input channels

(IS segregated and fully floating when used with MTL3052)

Location of input sources

Location of unit

Number of data highways

Power requirement

Multi-transmitter facility

Ambient temperature limits

Weight

Typical response time

(input to receiver output)

Electrical safety (each input circuit)

Input sensor cable parameters

BASEEFA values (C,L or L/R)

(IIC)

(IIB)

(IIA)

Electrical safety (data highway circuit[s]) maximum input parameters

MTL831B (mV input)

16 THC or mV sources, potentiometer inputs up to 1kΩ
15 (RTD or mixed)

Zone 0, IIC, T4

Zone 0, IIC, T4

Dual redundant (either or both)

Loop-powered through data highway from receiver

No hazardous-area power supply required

1 or 2

-20 to +60°C working

-40 to +80°C storage

1.3kg

1s for each transmitter

U_{max:out} = 15V

I_{max:out} = 16.3mA

W_{max:out} = 60mW

0.58μF, 127mH or 535μH/Ω

3.55μF, 486mH or 1087μH/Ω

14μF, 903mH or 1087μH/Ω

U_{max:in} = 30V

I_{max:in} = 300mA

W_{max:in} = 1.2W

C_{eq} = 0, L_{eq} = 0

ADDITIONAL SPECIFICATIONS

MTL831B

Each input terminal block is user-selectable by switch for mixed mV, THC, 2- or 4-wire RTD input or 3-wire RTD input.

Measuring ranges

±60mV or ±25mV or ±10mV, auto ranging

Common mode voltage

Maximum 5V common mode between input channels of one transmitter

mV signals

Accuracy at 20°C (including non-linearity and hysteresis)

<0.1% of measuring range

Temperature effects on accuracy

{(greater of 0.01% of range or 2μV) + 0.01% of reading} /°C

Thermocouple signals

Accuracy at 20°C (including non-linearity and hysteresis)

<0.1% of measuring range ±0.7°C

Upscale/downscale drive does not introduce any accuracy errors

Temperature effects on accuracy

{(greater of 0.01% of range or 2μV) + 0.01% of reading + 0.03°C} /°C

RTD signals

RTD range

-200 to +850°C (Pt100 type, DIN 43760, IEC751: 1983)

RTD excitation current

100μA

Accuracy at 20°C (including non-linearity and hysteresis)

<0.1% of measuring range

Temperature effects on accuracy

{(greater of 0.01% of range or 0.025°C) + 0.005% of reading} /°C

The given data is only intended as a product description and should not be regarded as a legal warranty of properties or guarantee. In the interest of further technical developments, we reserve the right to make design changes.



EUROPE (EMEA)

AMERICAS

ASIA PACIFIC

E-mail: enquiry@mtl-inst.com Web site: www.mtl-inst.com

Tel: +44 (0)1582 723633

Tel: +1 281 571 8065

Tel: +65 6 487 7887

Fax: +44 (0)1582 422283

Fax: +1 281 571 8069

Fax: +65 6 487 7997

Oct 2008

MTL838B-MBF RECEIVERS

BASIC SPECIFICATIONS

(see also 'Common specification')

Number of data highways	MTL838B-MBF
Location of unit	(Modbus® output)
Input noise rejection	2, dual redundant (either or both may be used) Safe area Up to 0.5mA peak-to-peak at 100 to 1000Hz, or up to 1mA peak-to-peak at 50Hz
Type of output(s)	Dual RS485 Modbus® protocol
System protocol	Modbus® ASCII or RTU
Serial communication parameters	Baud rate: 300 to 19200 Stop bits: 1 or 2 Data bits: 7 or 8 Parity bit: odd, even or none
Multi-receiver facility	Up to 31 MTL838B-MBF units can be connected to communicate with one Modbus® master controller
Power requirement	500mA at 20–35V dc
Ambient temperature limits	–20 to +50°C working –40 to +80°C storage
Weight	840g

ADDITIONAL SPECIFICATIONS

MTL838B-MBF

Thermocouple range supported

Types E, J, K, N, R and T THCs to IEC 584. Other options are available, please contact MTL for details.

System configuration

Serial communications parameters and system parameters entered using PCS83 software program, by downloading from process controller. Configuration parameters are retained by using battery-backed RAM.

Linearisation

Multi breakpoint calculation by microprocessor (output is linearised and cold junction compensated)

Broken THC indication

Serial output drives upscale or downscale

Alarm facilities

High and low alarms are indicated in the serial data and can be set for each input

The given data is only intended as a product description and should not be regarded as a legal warranty of properties or guarantee. In the interest of further technical developments, we reserve the right to make design changes.



EUROPE (EMEA)
AMERICAS
ASIA PACIFIC
E-mail: enquiry@mtl-inst.com

Tel: +44 (0)1582 723633
Tel: +1 281 571 8065
Tel: +65 6 487 7887

Fax: +44 (0)1582 422283
Fax: +1 281 571 8069
Fax: +65 6 487 7997

Web site: www.mtl-inst.com

Oct 2008

MTL3052

DIGITAL ISOLATOR

for signals up to 10kHz



This unit is similar in principle to the MTL3042 but operates at a higher frequency for use with digital signals. Its primary application is to provide IS protection for the data highways and transmitters in MTL800 Series multiplexer systems. The MTL3052 features two output circuits: one with a 15V, 180Ω safety description, and an alternative 15V, 100Ω circuit which can be used if higher loop resistances need to be accommodated, for example when surge protectors are incorporated in the data highways. If the low-resistance outputs are used on two units fitted to a dual-highway system however, the multiplexer transmitters are restricted to location in IIB atmospheres.

SPECIFICATION

See also 'Common specification'

Number of channels

One, fully floating

Location of load

Zone 0, IIC, T4-6 hazardous area if suitably certified
 Div 1, Group A, hazardous location
 Zone 0, IIB, T4-6 (Div 1, Group C, hazardous location)
 for multiplexer transmitters in dual-highway systems using the low-resistance outputs of two MTL3052s

Input voltage

4 to 12V dc

Signal bandwidth

dc to 10kHz

Minimum output voltage

$[V_{in} \text{ minus } (0.25 \times \text{current in mA})]$ V

Input and output circuit ripple

<1mA peak-to-peak

Power dissipation within unit

160mW maximum at 12V with 20mA signal

Replaceable fuse

50mA, 5 x 20mm glass to DIN 41571 sht. 2, semi-time-lag (M)

'No-fail' earth fault protection (optional)

Enabled by connecting terminal 8 to MTL4220
 Fault on either line proclaimed: unit continues working

Safety description

Terminals 5 & 6

15V, 100Ω, 150mA, $U_m = 250V$ rms or dc

Terminals 7 & 8

15V, 180Ω, 83.3mA, $U_m = 250V$ rms or dc

FM max entity parameters

$V_{oc} = 15V$, $I_{sc} = 83.3mA$, $C_a = 0.75\mu F$, $L_a = 5.2mH$

Weight

130g

Cable parameters - BASEEFA values (data highway circuits, each highway)

Grp	Terminals 7 & 8			Terminals 5 & 6		
	C μF	L mH	L/R μH/Ω	C μF	L mH	L/R μH/Ω
IIC	0.58	5.2	109	0.58	1.65	65
IIB	3.55	15.6	327	3.55	4.95	195
IIA	14	41.6	872	14	13.2	520

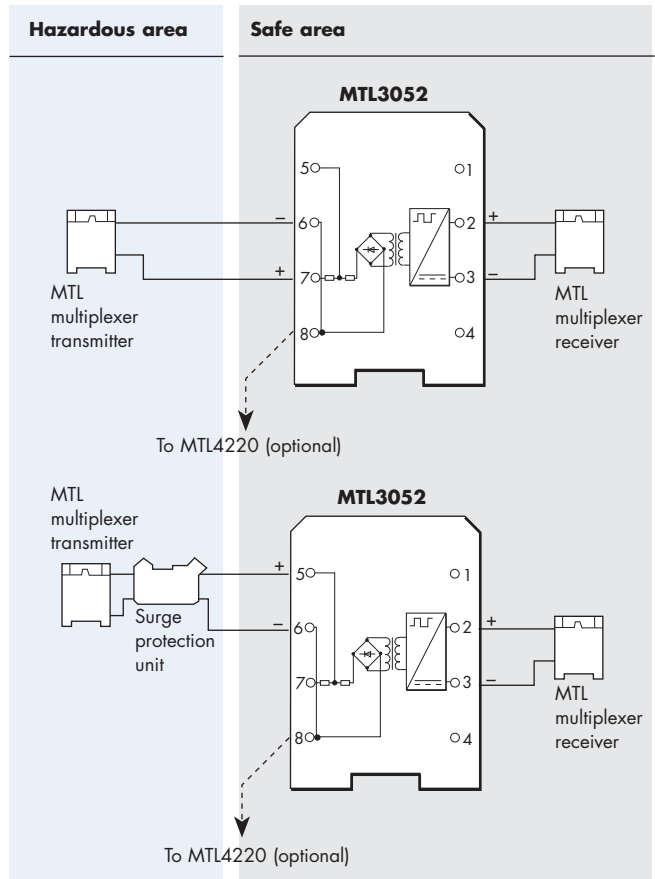

OTHER APPLICATIONS

The MTL3052 is suitable for a variety of other applications, such as bringing back the status of a hazardous-area mechanical or opto-transistor switch, or a magnetic shaft encoder (all via suitable current limiting resistors).

The given data is only intended as a product description and should not be regarded as a legal warranty of properties or guarantee. In the interest of further technical developments, we reserve the right to make design changes.



MTL800 SERIES COMMON SPECIFICATION

Humidity

5–95% RH (without condensation)

EMC compliance

EN 50081-2/EN 50082-2, generic emission/immunity standards.
These refer to appropriate IEC/CISPR standards.

Terminals

Detachable, each accommodates two 2.5mm² conductors

Casings

Moulded polycarbonate

CONDITIONS OF USE

The conditions governing the use of MTL800 Series multiplexers are given in the relevant certificates and schedules, copies of which are available from MTL.

DIMENSIONS (mm)

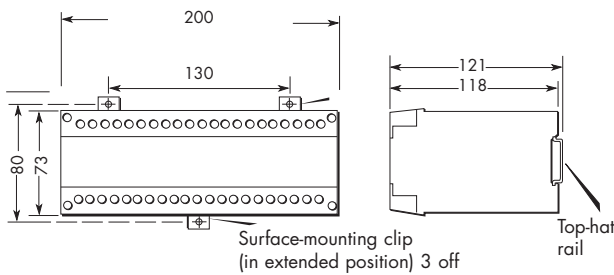

MTL800 SERIES SYSTEM SPECIFICATION

Maximum loop impedance (each data highway)

50Ω when using MTL3052 interface (terminals 7 & 8)
130Ω when using MTL3052 interface (terminals 5 & 8)
300Ω for non-IS applications

Transmission distance (transmitter to receiver)

0.5km typically (IS applications)
1.5km typically (non-IS applications)
For many applications it is possible to use longer distances up to 3km, for details consult MTL

Intrinsically safe interface (IS applications)

1 MTL3052 isolating interface unit for each data highway

Earth fault protection (optional)

An optional MTL4220 earth leakage detector will detect line-to-earth faults on either line of either highway.

Data highway monitoring

Highway 1 LED, green (located on receiver)

ON when highway 1 connected and operating

Highway 2 LED, green (located on receiver)

ON when highway 2 connected and operating

Highway 1 & 2 status

Serial output receivers: condition of highway(s) transmitted in unit status word to process controller

System failure monitoring

System failure LED, red (located on receiver)

ON when both highways disconnected or faulty or when there is an internal receiver fault

System failure signal

Serial output receivers: derived from status word

Power supply failure

All relays and LEDs de-energise

APPROVALS

Country	Canada	Czech	Russia	UK	USA
---------	--------	-------	--------	----	-----

MTL831B

(Authority)	(CSA)	(FTZU)	(GosGor TechNadzor)	(BASEEFA)	(FM)
Standard	C22.2 No.157	CSN EN 50014 CSN EN 50020	–	EN 50014 EN 50020 EN 50284	3610 Entity
Approved for	Class 1, Div 1, Gps A-D	Ex ia IIC T4	EEx ia IIC T4	EEx ia IIC T4	Class 1, Div 1, Gps A-D
Certificate/ File No.	1192829	FTZU98Ex0025	PPC00-25146	03ATEX0006X	J1.5B0A8.AX-1

MTL3052

(Authority)	(CSA)	(FTZU)	(GosGor TechNadzor)	(BASEEFA)	(FM)
Standard	C22.2 No.157	CSN E33 0380	–	EN 50014 EN 50020	3610 Entity
Approved for	Class 1, II, III Div 1, Gps A-G	[Ex ia IIC]	[Ex ia] IIC T4	[EEx ia] IIC	Class 1, II, III Div 1, Gps A-G
Certificate/ File No.	LR36637-42	J02043	PPC00-25146	03ATEX0034	J1.10Q4A0.AX

The given data is only intended as a product description and should not be regarded as a legal warranty of properties or guarantee. In the interest of further technical developments, we reserve the right to make design changes.



EUROPE (EMEA)
AMERICAS
ASIA PACIFIC
E-mail: enquiry@mtl-inst.com

Tel: +44 (0)1582 723633
Tel: +1 281 571 8065
Tel: +65 6 487 7887

Fax: +44 (0)1582 422283
Fax: +1 281 571 8069
Fax: +65 6 487 7997

Web site: www.mtl-inst.com

MTL800 SERIES ENCLOSURES

SPECIFICATIONS

ENC8/ENC8SS: for
1 MTL831B transmitter, or
1 MTL838B receiver

ENC83/ENC83SS: for
1 MTL831B transmitter
(for use with 4-wire RTDs)

Location

Zone 0, 1 or 2

Protection

Dust-tight and waterproof to IEC529:IP67

Construction (ENC8 and ENC83)

Sheet steel, zinc sprayed and painted RAL7015 grey

Construction (ENC8SS and ENC83SS)

Stainless steel

Lid

Detachable with lift-off hinges, secured by captive fixing screws with a padlock hasp

Earth terminals

Fitted on internal earth rails; accommodate conductors up to 4mm²

Number of earth terminals

ENC8/ENC8SS: 22
ENC83/ENC83SS: 18

4-wire RTD terminals (ENC83/ENC83SS only)

32 ready-mounted terminals to accommodate conductors up to 4mm²

Gland fixing

Top and bottom gland plates detachable for drilling by user

Mounting

By fixed mounting lugs

Weight (excl. transmitters/receivers)

ENC8: 7kg
ENC83: 9.8kg

DIMENSIONS (mm)

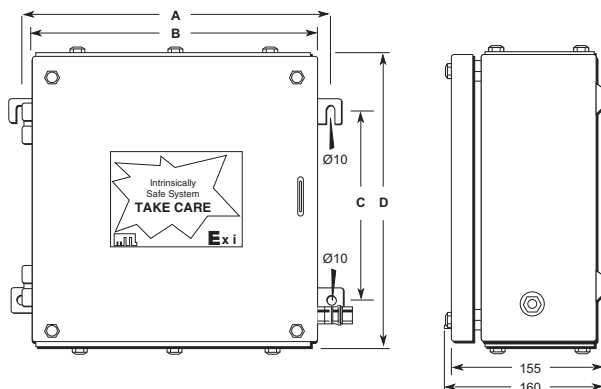

	A	B	C	D
ENC8	331	306	203	306
ENC83	407	380	305	466

MTL800 SERIES ACCESSORIES

SPECIFICATIONS

PCS83 SOFTWARE PACKAGE (FOR MTL838B-MBF)

Function: Software configuration of multiplexer system
Format: 3.5 inch diskette
Requires: PC with DOS 2.2, or higher, and a serial (COM) port.

TO ORDER, specify:

Transmitters

MTL831B Analogue transmitter

Receivers

MTL838B-MBF Analogue receiver, RS485 and/or RS422 outputs for Modbus®

Analogue receiver accessories

PCS83 PC software configuration package

Process controller interface software

Contact MTL for details of software for interfacing with proprietary process controllers

Isolating interface units and earth leakage detectors

MTL3052 Digital isolator interface unit
MTL4220 Earth leakage detector

Enclosures

ENC8 General-purpose enclosure
ENC8SS General-purpose enclosure (stainless steel)
ENC83 Enclosure for MTL831B transmitter
ENC83SS Enclosure for MTL831B transmitter (stainless steel)

Literature

INM838B-MBF System protocol manual:
MTL838B-MBF Modbus® receivers
INM831B MTL831B manual
AN9010 Application Note:
A user's guide to intrinsically safe input multiplexer systems
INS831B MTL831B mV Multiplexer transmitter
INS838B MTL838B-MBF Multiplexer receiver -
Modbus® output

The given data is only intended as a product description and should not be regarded as a legal warranty of properties or guarantee. In the interest of further technical developments, we reserve the right to make design changes.

