

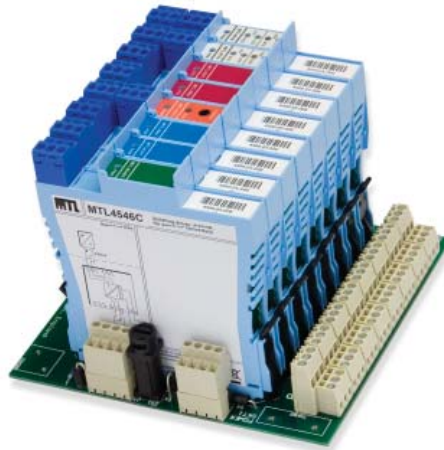

for close integration of
IS circuits into process-
connected systems

MTL4500 SERIES



- ◆ Compact modular design with 'plug-in' connections
- ◆ Quick install and release mechanism
- ◆ High module/channel packing densities
- ◆ System backplanes with bussed power and safe-area connections
- ◆ Custom-designed backplanes for closest integration into process-connected systems
- ◆ Compatible with MTL4000 Series interface family

The **MTL4500 Series** of isolating interface units introduces key concepts for integrating intrinsic safety into large or medium sized process-connected systems. Being exceptionally compact, the units give high packing densities and plug into system backplanes with safe-area connections made by multiway connectors – an approach which not only simplifies engineering but also reduces installation and maintenance costs. MTL4500 modules are held on the backplane with plastic clips that are simple to use, secure in operation and avoid the use of screws, giving further reduction in installation and maintenance time and cost.

Input and output modules handle normal process applications covering on/off or analogue signals between hazardous-area equipment and safe-area systems. Modules incorporate proven intrinsically safe isolation techniques, internationally certified for protecting equipment and wiring in all zones and explosive atmospheres. Input, output and power-supply circuits are isolated from each other, giving maximum flexibility for control loop applications.

Key module design features include a multiway connector to the backplane for safe-area and power supply connections. Hazardous-area connections simply plug into the front of the module; this simplifies installation and maintenance and reduces time, cost, and the risk of errors. Status LEDs, configuration switches and ports are located on the top or side of individual modules for easy access. The compact, 16mm wide, design reduces weight and gives exceptionally high packing density.

Based on proven IS isolation technology, MTL4500 Series modules do not need a high integrity earth and the associated circuits can be left floating or be earthed at any one point in accordance with good earthing practices. MTL4500 Series provides single channel single loop integrity across the range with the addition of dual channel options for the switch/proximity modules, analogue inputs and analogue outputs. There is even a quad channel switch/proximity input module for the maximum channel density.

Line fault detection (LFD) facilities are provided across the range of I/O functions; on the switch/proximity detectors, the MTL4523 solenoid/alarm driver and the isolating drivers. Analogue input units such as the MTL4541 provide line fault detection by repeating o/c or s/c currents to the safe-area control system.

System backplanes are located in safe areas and, because the hazardous-area circuits are connected directly to the modules, do not need to be certified. See MTL series backplanes, enclosures and accessories for full details.

The easy migration from MTL4000 supports existing installations because MTL4500 modules can be mounted on backplanes that were designed for MTL4000. A simple modification uses the backplane mounting holes of the MTL4000 to accept the mounting clips for the MTL4500 modules. This ensures continued availability and operation of process plant with new I/O modules and enhanced functionality.



MTL4500 I/O MODULE LIST

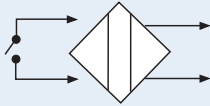

DIGITAL INPUT

Part Number	Functions
MTL4510	4ch DI solid-state output
MTL4510B	4ch DI multifunction solid-state output
MTL4511	1ch DI relay output
MTL4513	2ch DI solid-state output
MTL4514	1ch DI relay output + LFD alarm
MTL4516	2ch DI relay output
MTL4516C	2ch DI with changeover relay output
MTL4517	2ch DI relay output + LFD alarm

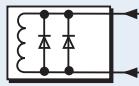

DIGITAL OUTPUT

Part Number	Functions
MTL4521	Loop powered solenoid driver
MTL4523	Solenoid driver with LFD
MTL4523R	Solenoid driver with LFD
MTL4523L	Loop powered solenoid driver + LFD
MTL4524	Switch operated solenoid driver
MTL4524S	Switch operated solenoid driver, 24V override
MTL4525	Switch operated solenoid driver low power

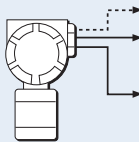

ANALOGUE INPUT

Part Number	Functions
MTL4541	1ch 2/3 wire Transmitter repeater
MTL4541B	1ch 2/3 wire Transmitter repeater, 2 port isolation
MTL4541P	1ch 2/3 wire Transmitter repeater, high power
MTL4544	2ch 2/3 wire Transmitter repeater
MTL4544B	2ch 2/3 wire Transmitter repeater, 2 port isolation

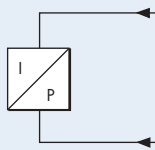

ANALOGUE OUTPUT

Part Number	Functions
MTL4546	1ch 4-20mA smart isolating driver + LFD
MTL4546C	1ch 4-20mA smart isolating driver + oc LFD
MTL4549	2ch 4-20mA smart isolating driver + LFD
MTL4549C	2ch 4-20mA smart isolating driver + oc LFD

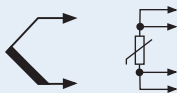

TEMPERATURE INPUT

Part Number	Functions
MTL4575	Temperature converter

GENERAL

Part Number	Functions
MTL4599	Dummy isolator
MTL4599N	General purpose feed-through module



MTL4510 SWITCH/ PROXIMITY DETECTOR INTERFACE

four-channel, digital input

The MTL4510 enables four solid-state outputs in the safe area to be controlled by up to four switches or proximity detectors located in a hazardous area. Each pair of output transistors shares a common terminal and can switch +ve or -ve polarity signals. A range of module configurations is available (see Table 1) through the use of selector switches. When proximity detector modes are selected, LFD is enabled and the output switches to OFF if a line fault is detected.

SPECIFICATION

See also common specification

Number of channels

4, configured by switches

Location of switches

Zone 0, IIC, T6 hazardous area
Div 1, Group A hazardous location

Location of proximity detectors

Zone 0, IIC, T4-6 hazardous area if suitably certified
Div 1, Group A, hazardous location

Hazardous-area inputs

Inputs conforming to BS EN60947-5-6:2001 standards for proximity detectors (NAMUR)

Voltage applied to sensor

7 to 9V dc from 1kΩ ±10%

Input/output characteristics

Normal phase

Outputs closed if input > 2.1mA (< 2kΩ in input circuit)

Outputs open if input < 1.2mA (> 10kΩ in input circuit)

Hysteresis: 200µA (650Ω) nominal

Line fault detection (LFD) (when selected)

User-selectable via switches on the side of the unit.

Open-circuit alarm on if $I_{in} < 50\mu A$

Open-circuit alarm off if $I_{in} > 250\mu A$

Short-circuit alarm on if $R_{in} < 100\Omega$

Short-circuit alarm off if $R_{in} > 360\Omega$

Note: Resistors must be fitted when using the LFD facility with a contact input

500Ω to 1kΩ in series with switch

20kΩ to 25kΩ in parallel with switch

Safe-area outputs

Floating solid-state outputs compatible with logic circuits

Operating frequency: dc to 500Hz

Max. off-state voltage: ± 35V

Max. off-state leakage current: ± 50µA

Max. on-state resistance: 65Ω

Max. on-state current: ± 50mA

LED indicators

Green: power indication

Yellow: four: indicates output active

Red: indicates line fault + faulty channel's yellow LED flashes

Maximum current consumption

40mA at 24V (with all output channels energised)

Power dissipation within unit

0.96W at 24V

Safety description (each channel)

$V_o=10.5V$ $I_o=14mA$ $P_o=37mW$ $U_m = 253V$ rms or dc

Hazardous area

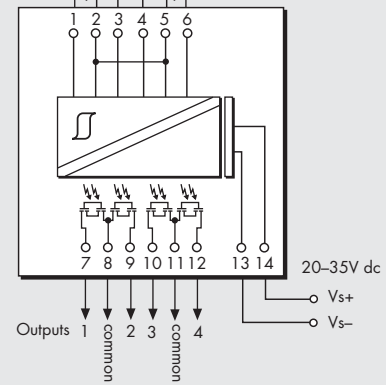
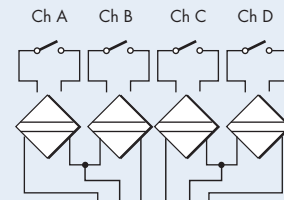

Safe area

Terminal	Function
1	Input channel A
2	Input channel AB common (+)
3	Input channel B
4	Input channel C
5	Input channel CD common (+)
6	Input channel D
7	Output channel 1
8	Output channel 1/2 common
9	Output channel 2
10	Output channel 3
11	Output channel 3/4 common
12	Output channel 4
13	Supply -ve
14	Supply +ve

Table 1 - Mode options

MODE	o/p 1	o/p 2	o/p 3	o/p 4	i/p type
0	chA	chB	chC	chD	switch
1	chA rev.	chB	chC	chD	
2	chA	chB rev.	chC	chD	
3	chA	chB	chC rev.	chD	
4	chA	chB	chC	chD rev.	
5	chA rev.	chB	chC rev.	chD	
6	chA	chB rev.	chC	chD rev.	
7	chA rev.	chB rev.	chC rev.	chD rev.	prox. detector + LFD
8	chA	chB	chC	chD	
9	chA rev.	chB	chC	chD	
10	chA	chB rev.	chC	chD	
11	chA	chB	chC rev.	chD	
12	chA	chB	chC	chD rev.	
13	chA rev.	chB	chC rev.	chD	
14	chA	chB rev.	chC	chD rev.	
15	chA rev.	chB rev.	chC rev.	chD rev.	

See Instruction Manual INM4500 for further mode information.



MTL4510B SWITCH/ PROXIMITY DETECTOR INTERFACE

four-channel, multi-function, digital input

The MTL4510B enables four solid-state outputs in the safe area to be controlled by up to four switches or proximity detectors located in a hazardous area. Each pair of output transistors shares a common terminal and can switch +ve or -ve polarity signals. A range of module configurations is available (see Table 1) through the use of selector switches. These include start/stop operations and pulse output modes.

SPECIFICATION

See also common specification

Number of channels

4, configured by switches

Location of switches

Zone 0, IIC, T6 hazardous area
Div 1, Group A hazardous location

Location of proximity detectors

Zone 0, IIC, T4-6 hazardous area if suitably certified
Div 1, Group A, hazardous location

Hazardous-area inputs

Inputs conforming to BS EN60947-5-6:2001 standards for proximity detectors (NAMUR)

Voltage applied to sensor

7 to 9V dc from 1kΩ ±10%

Input/output characteristics

Normal phase

Outputs closed if input > 2.1mA (< 2kΩ in input circuit)

Outputs open if input < 1.2mA (> 10kΩ in input circuit)

Hysteresis: 200µA (650Ω) nominal

Line fault detection (LFD) (when selected)

User-selectable via switches on the side of the unit.

Open-circuit alarm on if $I_{in} < 50\mu A$

Open-circuit alarm off if $I_{in} > 250\mu A$

Short-circuit alarm on if $R_{in} < 100\Omega$

Short-circuit alarm off if $R_{in} > 360\Omega$

Note: Resistors must be fitted when using the LFD facility with a contact input

500Ω to 1kΩ in series with switch

20kΩ to 25kΩ in parallel with switch

Safe-area outputs

Floating solid-state outputs compatible with logic circuits

Operating frequency: dc to 500Hz

Max. off-state voltage: ± 35V

Max. off-state leakage current: ± 50µA

Max. on-state resistance: 65Ω

Max. on-state current: ± 50mA

LED indicators

Green: power indication

Yellow: four: indicates output active

Red: LFD indication + faulty channel's yellow LED flashes

Maximum current consumption

40mA at 24V (with all output channels energised)

Power dissipation within unit

0.96 W at 24V

Safety description (each channel)

$V_o=10.5V$ $I_o=14mA$ $P_o=37mW$ $U_m = 253V$ rms or dc

Hazardous area

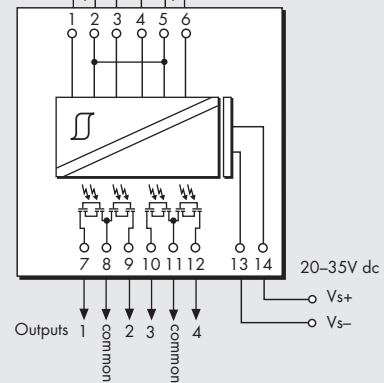
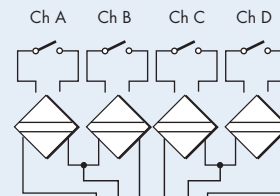

Safe area

Terminal	Function
1	Input channel A
2	Input channel AB common (+)
3	Input channel B
4	Input channel C
5	Input channel CD common (+)
6	Input channel D
7	Output channel 1
8	Output channel 1/2 common
9	Output channel 2
10	Output channel 3
11	Output channel 3/4 common
12	Output channel 4
13	Supply -ve
14	Supply +ve

Table 1 - Mode options

MODE	Function	Equivalent
0	4-ch switch input,	MTL4510
1	2-ch each channel one input, two outputs	MTL4016
2	Same as mode 1 with phase reversed	MTL4016
3	2-ch, 2-pole changeover output	
4	1-ch with line fault output	MTL4014
5	As mode 4 with changeover outputs	
6	1-ch with start-stop latch	MTL2210B
7	4-ch switch input,	MTL4510
8	4-ch switch input,	MTL4510
9	2-ch with line fault output	MTL4017
10	As mode 9 with LFD changeover	
11	As mode 10 with phase reversed	
12	3-ch with normally-open LFD output	
13	3-ch with normally-closed LFD output	
14	2-ch monostable, pulse stretcher	
15	4-ch switch input	MTL4510

See Instruction Manual INM4500 for further mode information.



MTL4511 SWITCH/ PROXIMITY DETECTOR INTERFACE

single channel, with line fault detection

The MTL4511 enables a safe-area load to be controlled by a switch or proximity detector located in a hazardous-area. When selected, open or short circuit conditions in the field wiring are detected by the line-fault-detect (LFD) facility and also indicated on the top of the module. Phase reversal for the channel is selected by a switch on the side of the module and output is provided by changeover relay contacts.

SPECIFICATION

See also common specification

Number of channels

One

Location of switches

Zone 0, IIC, T6 hazardous area

Div. 1, Group A hazardous location

Location of proximity detector

Zone 0, IIC, T4–6 hazardous area if suitably certified

Div. 1, Group A hazardous location

Hazardous-area inputs

Inputs conforming to BS EN60947-5-6:2001 standards for proximity detectors (NAMUR)

Voltage applied to sensor

7 to 9V dc from $1k\Omega \pm 10\%$

Input/output characteristics

Normal phase

Outputs closed if input $> 2.1mA$ ($< 2k\Omega$ in input circuit)

Outputs open if input $< 1.2mA$ ($> 10k\Omega$ in input circuit)

Hysteresis: $200\mu A$ (650Ω) nominal

Line fault detection (LFD) (when selected)

User-selectable via switches on the side of the unit. A line fault is indicated by an LED. The channel output relay is de-energised if an input line fault is detected.

Open-circuit alarm on if $I_{in} < 50\mu A$

Open-circuit alarm off if $I_{in} > 250\mu A$

Short-circuit alarm on if $R_{in} < 100\Omega$

Short-circuit alarm off if $R_{in} > 360\Omega$

Note: Resistors must be fitted when using the LFD facility with a contact input

500Ω to $1k\Omega$ in series with switch

$20k\Omega$ to $25k\Omega$ in parallel with switch

Safe-area output

Single pole relay with changeover contacts

Note: reactive loads must be adequately suppressed

Relay characteristics

Response time: 10ms maximum

Contact rating: 10W, 0.5A, 35V dc

Hazardous area

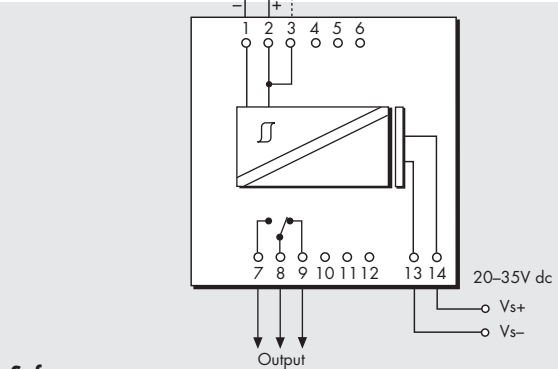
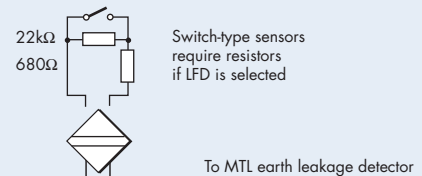

Safe area

Terminal	Function
1	Input -ve
2	Input +ve
3	To earth leakage detector*
7	Output normally-open contact
8	Common
9	Output normally-closed contact
13	Supply -ve
14	Supply +ve

*Signal plug HAZ1-3 is required for access to this function

LED indicators

Green: power indication

Yellow: channel status, on when output is energised

Red: LFD indication, on when line fault is detected

Maximum current consumption

30mA at 24V

Power dissipation within unit

0.72W at 24V

Safety description (each channel)

$V_o = 10.5V$ $I_o = 14mA$ $P_o = 37mW$ $U_m = 253V$ rms or dc



EUROPE (EMEA)

AMERICAS

ASIA PACIFIC

E-mail: enquiry@mtl-inst.com Web site: www.mtl-inst.com

Tel: +44 (0)1582 723633

Tel: +1 281 571 8065

Tel: +65 6 487 7887

Fax: +44 (0)1582 422283

Fax: +1 281 571 8069

Fax: +65 6 487 7997

MTL4513 SWITCH/ PROXIMITY DETECTOR INTERFACE

two-channel, with line fault detection
and phase reversal

The MTL4513 enables two solid-state outputs in the safe area to be controlled by two switches or proximity detectors located in the hazardous area. The Ch1/Ch2 output transistors share a common terminal and can switch +ve or -ve polarity signals. Independent output phase reversal and line fault detection are enabled via switches for each output. LFD indication is provided on the top of the module.

SPECIFICATION

See also common specification

Number of channels

Two

Location of switches

Zone 0, IIC, T6 hazardous area
Div. 1, Group A hazardous location

Location of proximity detectors

Zone 0, IIC, T4-6 hazardous area if suitably certified
Div. 1, Group A hazardous location

Hazardous-area inputs

Inputs conforming to BS EN60947-5-6:2001 standards for proximity detectors (NAMUR)

Voltage applied to sensor

7 to 9V dc from $1k\Omega \pm 10\%$

Input/output characteristics

Normal phase

Outputs closed if input $> 2.1mA$ ($< 2k\Omega$ in input circuit)

Outputs open if input $< 1.2mA$ ($> 10k\Omega$ in input circuit)

Hysteresis: $200\mu A$ (650Ω) nominal

Line fault detection (LFD) (when selected)

User-selectable for each channel via switches on the side of the unit. Line faults are indicated by an LED for each channel.

Open-circuit alarm on if $I_{in} < 50\mu A$

Open-circuit alarm off if $I_{in} > 250\mu A$

Short-circuit alarm on if $R_{in} < 100\Omega$

Short-circuit alarm off if $R_{in} > 360\Omega$

Note: Resistors must be fitted when using the LFD facility with a contact input 500Ω to $1k\Omega$ in series with switch

$20k\Omega$ to $25k\Omega$ in parallel with switch

Phase reversal

Independent for each channel, user-selectable

Safe-area outputs

Floating solid-state outputs compatible with logic circuits

Operating frequency: dc to 1kHz

Max. off-state voltage: $\pm 35V$

Max. off-state leakage current: $\pm 50\mu A$

Max. on-state resistance: 65Ω

Max. on-state current: $\pm 50mA$

Hazardous area

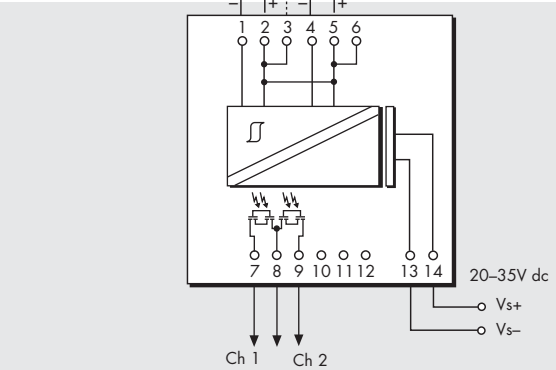
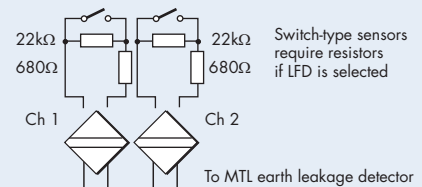

Safe area

Terminal	Function
1	Input -ve (Ch 1)
2	Input +ve (Ch 1)
3	To earth leakage detector*
4	Input -ve (Ch 2)
5	Input +ve (Ch 2)
6	To earth leakage detector*
7	Output (Ch 1)
8	Output (Ch 1/Ch 2)
9	Output (Ch 2)
13	Supply -ve
14	Supply +ve

*Signal plug HAZ1-3 is required for access to this function

LED indicators

Green: power indication

Yellow: two: channel status, on when outputs are on

Red: two: LFD indication, on when line fault detected

Maximum current consumption

30mA at 24V

Power dissipation within unit

0.9W typical at 24V with 10mA loads-

1.2W max. with 50mA loads

Safety description (each channel)

$V_o = 10.5V$ $I_o = 14mA$ $P_o = 37mW$ $U_m = 253V$ rms or dc



EUROPE (EMEA)
AMERICAS
ASIA PACIFIC
E-mail: enquiry@mtl-inst.com

Tel: +44 (0)1582 723633
Tel: +1 281 571 8065
Tel: +65 6 487 7887

Fax: +44 (0)1582 422283
Fax: +1 281 571 8069
Fax: +65 6 487 7997

Web site: www.mtl-inst.com

MTL4514 SWITCH/ PROXIMITY DETECTOR INTERFACE

single channel with line fault detection
and phase reversal

The MTL4514 enables a safe-area load to be controlled, through a relay, by a proximity detector or switch located in a hazardous area. Line faults are signalled through a separate relay and indicated on the top of the module. Switches are provided to select phase reversal and to enable the line fault detection.

SPECIFICATION

See also common specification

Number of channels

One

Location of switch

Zone 0, IIC, T6 hazardous area
Div.1, Group A, hazardous location

Location of proximity detector

Zone 0, IIC, T4-6 if suitably certified
Div.1, Group A, hazardous location

Hazardous-area inputs

Inputs conforming to BS EN60947-5-6:2001 standards for proximity detectors (NAMUR)

Voltage applied to sensor

7 to 9V dc from $1k\Omega \pm 10\%$

Input/output characteristics

Normal phase

Outputs closed if input $> 2.1mA$ ($< 2k\Omega$ in input circuit)

Outputs open if input $< 1.2mA$ ($> 10k\Omega$ in input circuit)

Hysteresis: $200\mu A$ (650Ω) nominal

Line fault detection (LFD) (when selected)

User-selectable via switches on the side of the unit. Line faults are indicated by an LED. Line fault relay is energised and channel output relay de-energised if input line-fault detected

Open-circuit alarm on if $I_{in} < 50\mu A$

Open-circuit alarm off if $I_{in} > 250\mu A$

Short-circuit alarm on if $R_{in} < 100\Omega$

Short-circuit alarm off if $R_{in} > 360\Omega$

Note: Resistors must be fitted when using the LFD facility with a contact input 500Ω to $1k\Omega$ in series with switch

$20k\Omega$ to $25k\Omega$ in parallel with switch

Safe-area output

Channel: Single pole relay with changeover contacts

LFD: Single pole relay with changeover contacts

Note: reactive loads must be adequately suppressed

Relay characteristics

Response time: 10ms maximum

Contact rating: 10W, 0.5A, 35V dc

Hazardous area

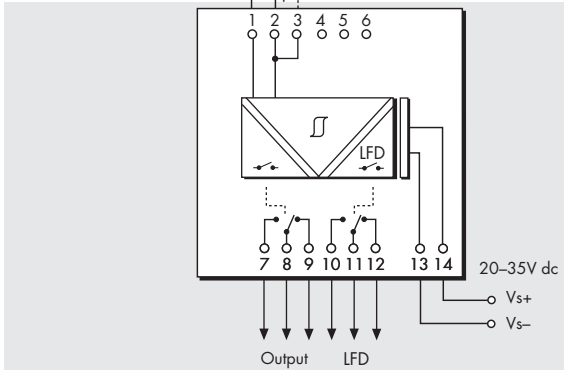
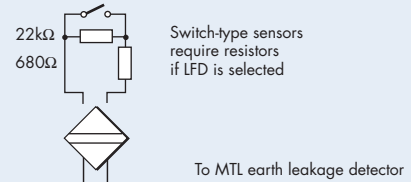

Safe area

Terminal	Function
1	Input -ve
2	Input +ve
3	To earth leakage detector*
7	Output NO contact
8	Output Common
9	Output NC contact
10	LFD NO contact
11	LFD Common
12	LFD NC contact
13	Supply -ve
14	Supply +ve

*Signal plug HAZ1-3 is required for access to this function

LED indicators

Green: power indication

Yellow: channel status, on when output circuit is closed

Red: LFD indication, on when line fault is detected

Maximum current consumption

35mA at 24V dc

Power dissipation within unit

0.72W at 24V

Safety description

$V_o=10.5V$ $I_o=14mA$ $P_o=37mW$ $U_m = 253V$ rms or dc



MTL4516 SWITCH/ PROXIMITY DETECTOR INTERFACE

two-channel, with line fault detection

The MTL4516 enables two safe-area loads to be controlled by a switch or proximity detector located in a hazardous-area. When selected, open or short circuit conditions in the field wiring are detected by the line-fault-detect (LFD) facility and also indicated on the top of the module. Phase reversal for each channel is selected by a switch on the side of the module and output is provided by relay contacts.

SPECIFICATION

See also common specification

Number of channels

Two

Location of switches

Zone 0, IIC, T6 hazardous area
Div. 1, Group A hazardous location

Location of proximity detector

Zone 0, IIC, T4-6 hazardous area if suitably certified
Div. 1, Group A hazardous location

Hazardous-area inputs

Inputs conforming to BS EN60947-5-6:2001 standards for proximity detectors (NAMUR)

Voltage applied to sensor

7 to 9V dc from $1k\Omega \pm 10\%$

Input/output characteristics

Normal phase

Outputs closed if input $> 2.1mA$ ($< 2k\Omega$ in input circuit)

Outputs open if input $< 1.2mA$ ($> 10k\Omega$ in input circuit)

Hysteresis: $200\mu A$ (650Ω) nominal

Line fault detection (LFD) (when selected)

User-selectable via switches on the side of the unit. Line faults are indicated by an LED for each channel. The channel output relay is de-energised if an input line fault is detected.

Open-circuit alarm on if $I_{in} < 50\mu A$

Open-circuit alarm off if $I_{in} > 250\mu A$

Short-circuit alarm on if $R_{in} < 100\Omega$

Short-circuit alarm off if $R_{in} > 360\Omega$

Note: Resistors must be fitted when using the LFD facility with a contact input

500Ω to $1k\Omega$ in series with switch

$20k\Omega$ to $25k\Omega$ in parallel with switch

Safe-area output

Two single-pole relays with normally-open contacts

Note: reactive loads must be adequately suppressed

Relay characteristics

Response time: 10ms maximum

Contact rating: 10W, 0.5A, 35V dc

Hazardous area

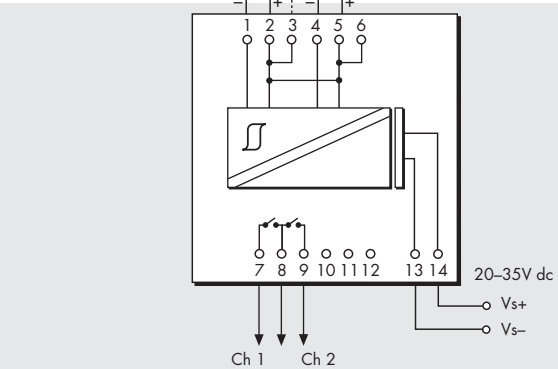
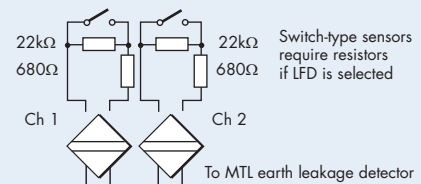

Safe area

Terminal	Function
1	Input -ve (Ch 1)
2	Input +ve (Ch 1)
3	To earth leakage detector*
4	Input -ve (Ch 2)
5	Input +ve (Ch 2)
6	To earth leakage detector*
7	Normally-open contact (Ch 1)
8	Common (Ch 1/Ch 2)
9	Normally-open contact (Ch 2)
13	Supply -ve
14	Supply +ve

*Signal plug HAZ1-3 is required for access to this function

LED indicators

Green: power indication

Yellow: two: channel status, on when output is energised

Red: two: LFD indication, on when line fault detected

Maximum current consumption

35mA at 24V

Power dissipation within unit

0.84W at 24V

Safety description (each channel)

$V_o = 10.5V$ $I_o = 14mA$ $P_o = 37mW$ $U_m = 253V$ rms or dc



EUROPE (EMEA)

AMERICAS

ASIA PACIFIC

E-mail: enquiry@mtl-inst.com

Tel: +44 (0)1582 723633

Tel: +1 281 571 8065

Tel: +65 6 487 7887

Web site: www.mtl-inst.com

Fax: +44 (0)1582 422283

Fax: +1 281 571 8069

Fax: +65 6 487 7997

MTL4516C SWITCH/ PROXIMITY DETECTOR INTERFACE

two-channel, with line fault detection

The MTL4516C enables two safe-area loads to be controlled by a switch or proximity detector located in a hazardous-area. When selected, open or short circuit conditions in the field wiring are detected by the line-fault-detect (LFD) facility and also indicated on the top of the module. Phase reversal for each channel is selected by a switch on the side of the module and output is provided by changeover relay contacts.

SPECIFICATION

See also common specification

Number of channels

Two

Location of switches

Zone 0, IIC, T6 hazardous area
Div. 1, Group A hazardous location

Location of proximity detector

Zone 0, IIC, T4-6 hazardous area if suitably certified
Div. 1, Group A hazardous location

Hazardous-area inputs

Inputs conforming to BS EN60947-5-6:2001 standards for proximity detectors (NAMUR)

Voltage applied to sensor

7 to 9V dc from $1k\Omega \pm 10\%$

Input/output characteristics

Normal phase

Outputs closed if input $> 2.1mA$ ($< 2k\Omega$ in input circuit)

Outputs open if input $< 1.2mA$ ($> 10k\Omega$ in input circuit)

Hysteresis: $200\mu A$ (650Ω) nominal

Line fault detection (LFD) (when selected)

User-selectable via switches on the side of the unit. Line faults are indicated by an LED for each channel. The channel output relay is de-energised if an input line fault is detected.

Open-circuit alarm on if $I_{in} < 50\mu A$

Open-circuit alarm off if $I_{in} > 250\mu A$

Short-circuit alarm on if $R_{in} < 100\Omega$

Short-circuit alarm off if $R_{in} > 360\Omega$

Note: Resistors must be fitted when using the LFD facility with a contact input

500Ω to $1k\Omega$ in series with switch

$20k\Omega$ to $25k\Omega$ in parallel with switch

Safe-area output

Two single-pole relays with changeover contacts

Note: reactive loads must be adequately suppressed

Relay characteristics

Response time: 10ms maximum

Contact rating: 10W, 0.5A, 35V dc

Hazardous area

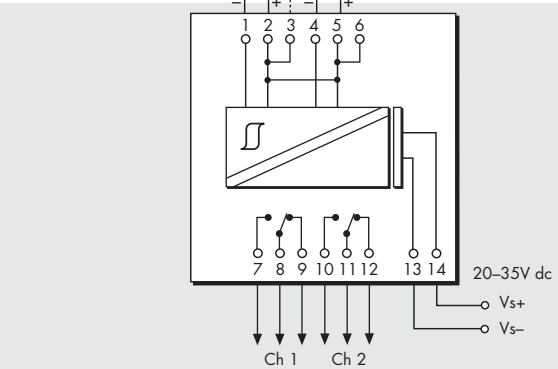
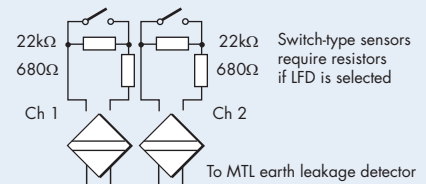

Safe area

Terminal	Function
1	Input -ve (Ch 1)
2	Input +ve (Ch 1)
3	To earth leakage detector*
4	Input -ve (Ch 2)
5	Input +ve (Ch 2)
6	To earth leakage detector*
7	Normally-open contact (Ch 1)
8	Common (Ch 1)
9	Normally-closed contact (Ch 1)
10	Normally-open contact (Ch 2)
11	Common (Ch 2)
12	Normally-closed contact (Ch 2)
13	Supply -ve
14	Supply +ve

*Signal plug HAZ1-3 is required for access to this function

LED indicators

Green: power indication

Yellow: two: channel status, on when output is energised

Red: two: LFD indication, on when line fault detected

Maximum current consumption

35mA at 24V

Power dissipation within unit

0.84W at 24V

Safety description (each channel)

$V_o=10.5V$ $I_o=14mA$ $P_o=37mW$ $U_m = 253V$ rms or dc



EUROPE (EMEA)

AMERICAS

ASIA PACIFIC

E-mail: enquiry@mtl-inst.com

Tel: +44 (0)1582 723633

Tel: +1 281 571 8065

Tel: +65 6 487 7887

Web site: www.mtl-inst.com

Fax: +44 (0)1582 422283

Fax: +1 281 571 8069

Fax: +65 6 487 7997

MTL4517 SWITCH/ PROXIMITY DETECTOR INTERFACE

two-channel with line fault detection
and phase reversal

The MTL4517 enables two safe-area loads to be controlled, through a relay, by proximity detectors or switches located in a hazardous area. Line faults are signalled through a separate relay and indicated on the top of the module. Switches are provided to select phase reversal and to enable the line fault detection.

SPECIFICATION

See also common specification

Number of channels

Two

Location of switch

Zone 0, IIC, T6 hazardous area
Div.1, Group A, hazardous location

Location of proximity detector

Zone 0, IIC, T4-6 if suitably certified
Div.1, Group A, hazardous location

Hazardous-area inputs

Inputs conforming to BS EN60947-5-6:2001 standards for proximity detectors (NAMUR)

Voltage applied to sensor

7 to 9V dc from $1k\Omega \pm 10\%$

Input/output characteristics

Normal phase

Outputs closed if input $> 2.1mA$ ($< 2k\Omega$ in input circuit)

Outputs open if input $< 1.2mA$ ($> 10k\Omega$ in input circuit)

Hysteresis: $200\mu A$ (650Ω) nominal

Line fault detection (LFD) (when selected)

User selectable by switches on the side of the module. Line faults are indicated by the LED for each channel.

Line fault relay is energised and channel output relay de-energised if input line-fault detected

Open-circuit alarm on if $I_{in} < 50\mu A$

Open-circuit alarm off if $I_{in} > 250\mu A$

Short-circuit alarm on if $R_{in} < 100\Omega$

Short-circuit alarm off if $R_{in} > 360\Omega$

Note: Resistors must be fitted when using the LFD facility with a contact input

500Ω to $1k\Omega$ in series with switch

$20k\Omega$ to $25k\Omega$ in parallel with switch

Safe-area output

Channel: Two single-pole relays with normally open contacts

LFD: Single pole relay with changeover contacts

Note: reactive loads must be adequately suppressed

Relay characteristics

Response time: 10ms maximum

Contact rating: 10W, 0.5A, 35V dc

Hazardous area

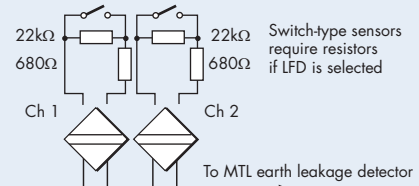

Safe area

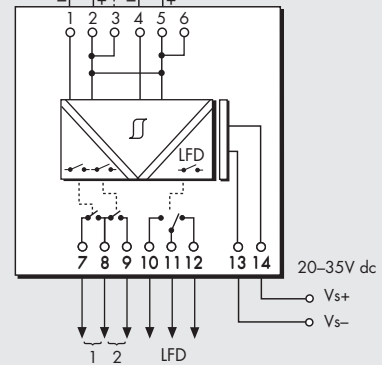

Safe area

Terminal	Function
1	Input -ve (Ch 1)
2	Input +ve (Ch 1)
3	To earth leakage detector*
4	Input -ve (Ch 2)
5	Input +ve (Ch 2)
6	To earth leakage detector*
7	Output 1
8	Common - Outputs 1 and 2
9	Output 2
10	LFD NO contact
11	LFD Common
12	LFD NC contact
13	Supply -ve
14	Supply +ve

*Signal plug HAZ1-3 is required for access to this function

LED indicators

Green: power indication

Yellow: two: channel status, on when output is energised

Red: two: LFD indication, on when line fault detected

Maximum current consumption

35mA at 24V

Power dissipation within unit

0.84W at 24V

Safety description (each channel)

$V_o=10.5V$ $I_o=14mA$ $P_o=37mW$ $U_m=253V$ rms or dc



EUROPE (EMEA)

Tel: +44 (0)1582 723633

Fax: +44 (0)1582 422283

AMERICAS

Tel: +1 281 571 8065

Fax: +1 281 571 8069

ASIA PACIFIC

Tel: +65 6 487 7887

Fax: +65 6 487 7997

E-mail: enquiry@mtl-inst.com

Web site: www.mtl-inst.com

MTL4521 SOLENOID/ ALARM DRIVER

loop-powered, IIC

The MTL4521 is a loop-powered module which enables a device located in the hazardous area to be controlled from the safe area. The MTL4521 can drive a certified intrinsically safe low-power load, as well as non-energy-storing simple apparatus such as an LED.

SPECIFICATION

See also common specification

Number of channels

One

Location of load

Zone 0, IIC, T4--6 hazardous area if suitably certified
Div. 1, Group A hazardous location

Minimum output voltage Equivalent output circuit

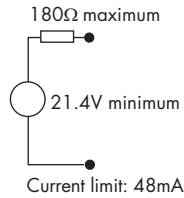
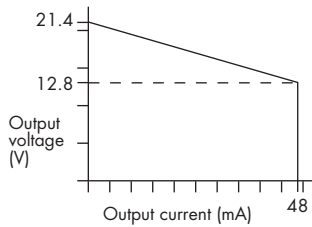

Input voltage

20 to 35V dc

Hazardous-area output

Minimum output voltage: 12.8V at 48mA
Maximum output voltage: 24V from 180Ω
Current limit: 48mA

Output ripple

< 0.5% of maximum output, peak to peak

Response time

Output within 10% of final value within 100ms

Hazardous area

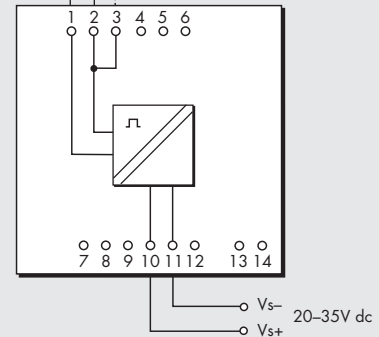
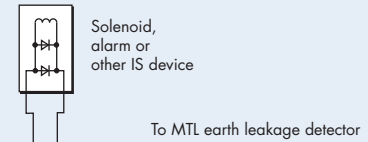

Safe area

Terminal	Function
1	Output -ve
2	Output +ve
3	To earth leakage detector*
10	Supply +ve
11	Supply -ve

*Signal plug HAZ1-3 is required for access to this function

LED indicator

Yellow: output status, on when output circuit is active

Maximum current consumption

90mA at 24V

Power dissipation within unit

1.4W at 24V

Safety description

$V_o=25V$ $I_o=147mA$ $P_o=919mW$ $U_m = 253V$ rms or dc

MTL4523/4523R

SOLENOID/ALARM DRIVER

with line fault detection, IIC

With the MTL4523 interface, an on/off device in a hazardous area can be controlled by a voltage signal in the safe area. It is suitable for driving loads such as solenoids. Line fault detection (LFD), which operates irrespective of the output state, is signalled by a safe-area solid-state switch which de-energises MTL4523, or energises MTL4523R, if a field line is open or short-circuited. Earth fault detection can be provided by connecting an MTL4220 earth leakage detector to terminal 3.

SPECIFICATION

See also common specification

Number of channels

One

Location of load

Zone 0, IIC, T4-6 hazardous area if suitably certified
Div. 1, Group A, hazardous location

Minimum output voltage

Equivalent output circuit

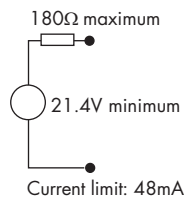
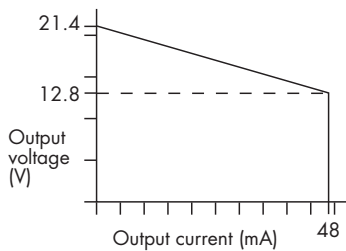

Hazardous-area output

Minimum output voltage: 12.8V at 48mA
Maximum output voltage: 24V from 180Ω
Current limit: 48mA

Output ripple

< 0.5% of maximum output, peak to peak

Control input

Suitable for switch contacts, an open collector transistor or logic drive
Output turns on if input switch closed, transistor on or < 1.4V applied across terminals 10 & 11
Output turns off if input switch open, transistor off or > 4.5V applied across terminals 10 & 11

Response time

Output within 10% of final value within 100ms

Line fault detection (LFD)

Open or short circuit in field cabling de-energises solid state line fault signal. (MTL4523R transistor is energised when line fault is detected)

LFD transistor is switched on (off MTL4523R), provided that the field circuit impedance is > 55Ω and < 6k5Ω.

Line fault signal characteristics

Maximum off-state voltage: 35V
Maximum off-state leakage current: 10μA
Maximum on-state voltage drop: 2V
Maximum on-state current: 50mA

Note: LFD signal is Zener-diode protected against inductive loads

Hazardous area

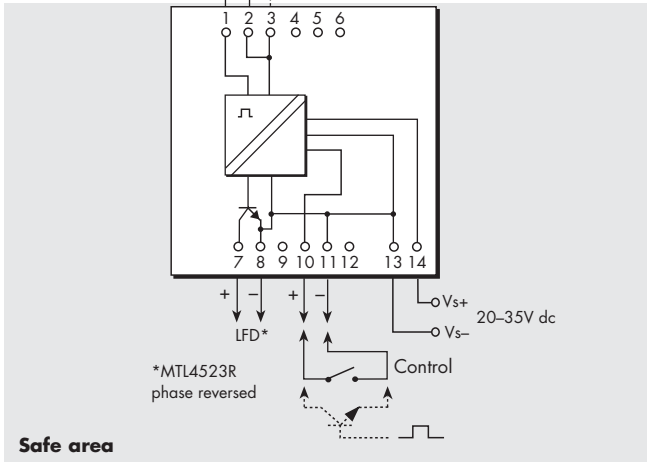
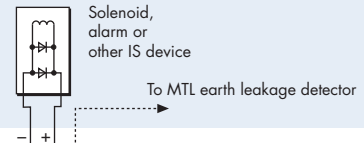

Safe area

Terminal	Function
1	Output -ve
2	Output +ve
3	To earth leakage detector*
7	Line fault signal +ve
8	Line fault signal -ve
10	Control +ve
11	Control -ve
13	Supply -ve
14	Supply +ve

*Signal plug HAZ1-3 is required for access to this function

LED indicators

Green: power indication
Yellow: output status, on when output circuit is active
Red: LFD indication, on when line fault is detected

Maximum current consumption

100mA at 24V dc

Power dissipation within unit

1.2W with typical solenoid valve, output on
2.0W worst case

Safety description

$V_o = 25V$ $I_o = 147mA$ $P_o = 919mW$ $U_m = 253V$ rms or dc



MTL4523L SOLENOID/ ALARM DRIVER

loop-powered with line fault detection, IIC

With the MTL4523L interface, an on/off device in a hazardous area can be controlled by a voltage signal in the safe area. It is suitable for driving loads such as solenoids. Line fault detection (LFD), which operates when the output is energised, is signalled by a safe-area solid-state switch which energises if a field line is open or short-circuited. Earth fault detection can be provided by connecting an MTL4220 earth leakage detector to terminal 3.

SPECIFICATION

See also common specification

Number of channels

One

Location of load

Zone 0, IIC, T4–6 hazardous area if suitably certified
Div. 1, Group A, hazardous location

Minimum output voltage Equivalent output circuit

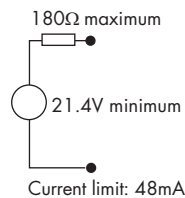
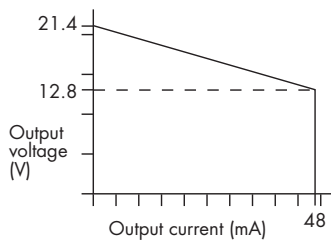

Input voltage

20 to 35V dc

Hazardous-area output

Minimum output voltage: 12.8V at 48mA
Maximum output voltage: 24V from 180Ω
Current limit: 48mA

Output ripple

< 0.5% of maximum output, peak to peak

Response time

Output within 10% of final value within 100ms

Line fault detection (LFD)

Open or short circuit in field cabling energises solid state line fault signal
LFD transistor is switched on, provided that the field circuit impedance is > 55Ω and < 6k5Ω.

Line fault signal characteristics

Maximum off-state voltage: 35V
Maximum off-state leakage current: 10μA
Maximum on-state voltage drop: 2V
Maximum on-state current: 50mA

Note: LFD signal is Zener-diode protected against inductive loads

Hazardous area

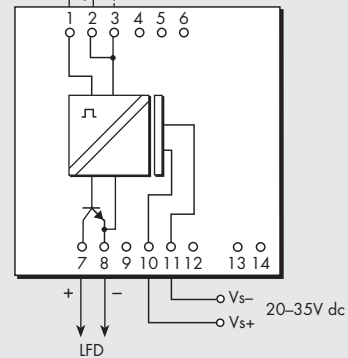
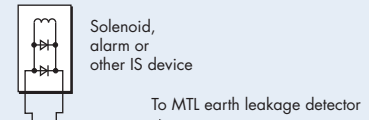

Safe area

Terminal	Function
1	Output -ve
2	Output +ve
3	To earth leakage detector*
7	Line fault signal +ve
8	Line fault signal -ve
10	Supply +ve
11	Supply -ve

*Signal plug HAZ1-3 is required for access to this function

LED indicators

Yellow: output status, on when output circuit is active
Red: LFD indication, on when line fault is detected

Maximum current consumption

100mA at 24V dc

Power dissipation within unit

1.2W with typical solenoid valve, output on

Safety description

$V_o=25V$ $I_o=147mA$ $P_o=919mW$ $U_m = 253V$ rms or dc

MTL4524 SOLENOID/ ALARM DRIVER

switch operated with override, IIC

The MTL4524 enables an on/off device in a hazardous area to be controlled by a volt-free contact or logic signal in the safe area. It can drive loads such as solenoids, alarms, LEDs and other low power devices that are certified as intrinsically safe or are classified as non-energy storing simple apparatus. By connecting a second safe-area switch or logic signal, the output can be disabled to permit, for example, a safety system to override a control signal.

SPECIFICATION

See also common specification

Number of channels

One

Location of load

Zone 0, IIC, T4-6 hazardous area if suitably certified
Div.1, Group A, hazardous location

Minimum output voltage

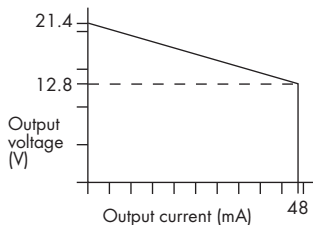

Equivalent output circuit

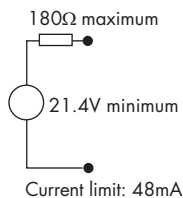

Hazardous-area output

Minimum output voltage: 12.8V at 48mA
Maximum output voltage: 24V from 180Ω
Current limit: 48mA

Output ripple

< 0.5% of maximum output, peak-to-peak

Control input

Suitable for switch contacts, an open collector transistor or logic drive

0 = input switch closed, transistor on or <1.4V applied across terminals 10 & 11

1 = input switch open, transistor off or >4.5V applied across terminals 10 & 11

Override input

An open collector transistor or a switch connected across terminals 8 and 9 can be used to turn the output off whatever the state of the control input

0 = transistor on or switch closed

1 = transistor off or switch open

Control and override inputs

Control input	Override input	Output state
0	0	off
0	1	on
1	0	off
1	1	off

Response time

Output within 10% of final value within 100ms

Hazardous area

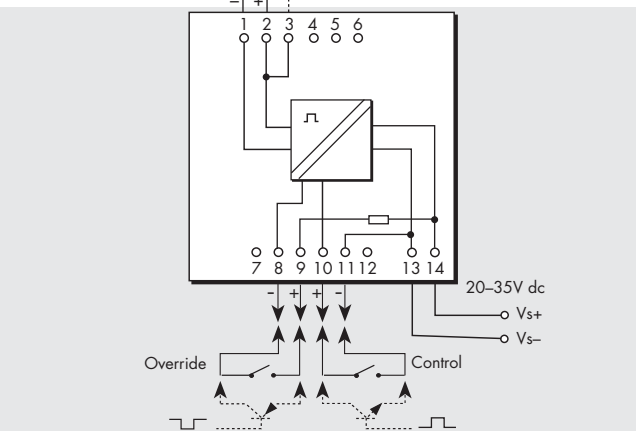
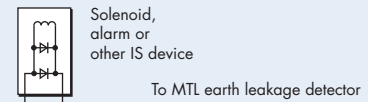

Safe area

Terminal	Function
1	Output -ve
2	Output +ve
3	To earth leakage detector*
8	Override -ve
9	Override +ve
10	Control +ve
11	Control -ve
13	Supply -ve
14	Supply +ve

*Signal plug HAZ1-3 is required for access to this function

LED indicators

Green: power indication

Yellow: output status, on when output circuit is active

Maximum current consumption

100mA at 24V dc

Power dissipation within unit

1.3W with typical solenoid valve, output on

1.9W worst case

Safety description

$V_o=25V$ $I_o=147mA$ $P_o=919mW$ $U_m = 253V$ rms or dc



MTL4524S SOLENOID/ ALARM DRIVER

switch operated with 24V override, IIC

The MTL4524S enables an on/off device in a hazardous area to be controlled by a volt-free contact or logic signal in the safe area. It can drive loads such as solenoids, alarms, LEDs and other low power devices that are certified as intrinsically safe or are classified as non-energy storing simple apparatus. By connecting a second safe-area voltage, the output can be disabled to permit, for example, a safety system to override a control signal.

SPECIFICATION

See also common specification

Number of channels

One

Location of load

Zone 0, IIC, T4-6 hazardous area if suitably certified
Div.1, Group A, hazardous location

Minimum output voltage

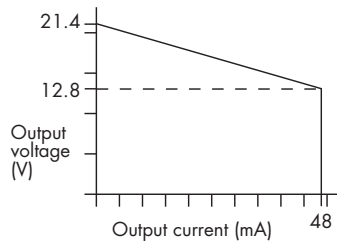

Equivalent output circuit

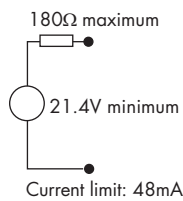

Hazardous-area output

Minimum output voltage: 12.8V at 48mA
Maximum output voltage: 24V from 180Ω
Current limit: 48mA

Output ripple

< 0.5% of maximum output, peak-to-peak

Control input

Suitable for switch contacts, an open collector transistor or logic drive

0 = input switch closed, transistor on or < 1.4V applied across terminals 10 & 11

1 = input switch open, transistor off or > 4.5V applied across terminals 10 & 11

Override input

A 24V logic signal applied across terminals 8 and 9 allows the solenoid/alarm to be operated by the control input. If it is disconnected, the solenoid/alarm is off.

0 = < 2.0V applied across terminals 8 & 9

1 = > 9.0V applied across terminals 8 & 9
(nominal switching point 4.5V)

Control and override inputs

Control input	Override input	Output state
0	0	off
0	1	on
1	0	off
1	1	off

Response time

Output within 10% of final value within 100ms

Hazardous area

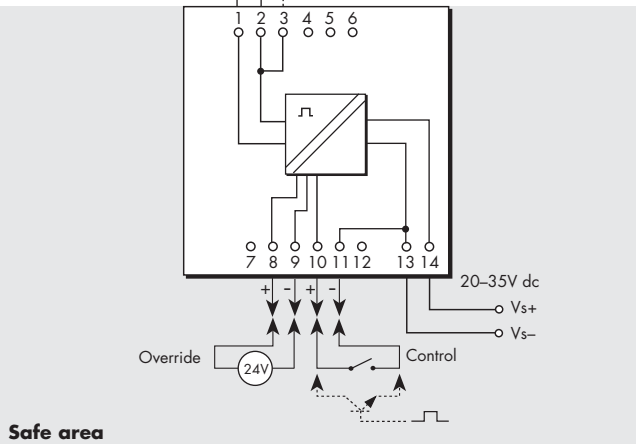
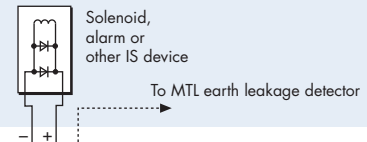

Safe area

Terminal	Function
1	Output -ve
2	Output +ve
3	To earth leakage detector*
8	Override +ve
9	Override -ve
10	Control +ve
11	Control -ve
13	Supply -ve
14	Supply +ve

*Signal plug HAZ1-3 is required for access to this function

LED indicators

Green: power indication

Yellow: output status, on when output circuit is active

Maximum current consumption

100mA at 24V dc

Power dissipation within unit

1.3W with typical solenoid valve, output on
1.9W worst case

Safety description

$V_o=25V$ $I_o=147mA$ $P_o=919mW$ $U_m = 253V$ rms or dc



MTL4525 SOLENOID/ ALARM DRIVER

switch operated with override, IIC

The MTL4525 enables an on/off device in a hazardous area to be controlled by a volt-free contact or logic signal in the safe area. It can drive loads such as solenoids, alarms, LEDs and other low power devices that are certified as intrinsically safe or are classified as non-energy storing simple apparatus. By connecting a second safe-area switch or logic signal, the output can be disabled to permit, for example, a safety system to override a control signal.

SPECIFICATION

See also common specification

Number of channels

One

Location of load

Zone 0, IIC, T4-6 hazardous area if suitably certified
Div.1, Group A, hazardous location

Minimum output voltage

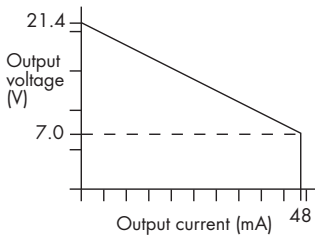

Equivalent output circuit

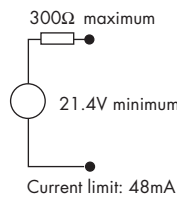

Hazardous-area output

Minimum output voltage: 7V at 48mA
Maximum output voltage: 24V from 300Ω
Current limit: 48mA

Output ripple

< 0.5% of maximum output, peak-to-peak

Control input

Suitable for switch contacts, an open collector transistor or logic drive

0 = input switch closed, transistor on or < 1.4V applied across terminals 10 & 11

1 = input switch open, transistor off or > 4.5V applied across terminals 10 & 11

Override input

An open collector transistor or a switch connected across terminals 8 and 9 can be used to turn the output off whatever the state of the control input

0 = transistor on or switch closed

1 = transistor off or switch open

Control and override inputs

Control input	Override input	Output state
0	0	off
0	1	on
1	0	off
1	1	off

Response time

Output within 10% of final value within 100ms

Hazardous area

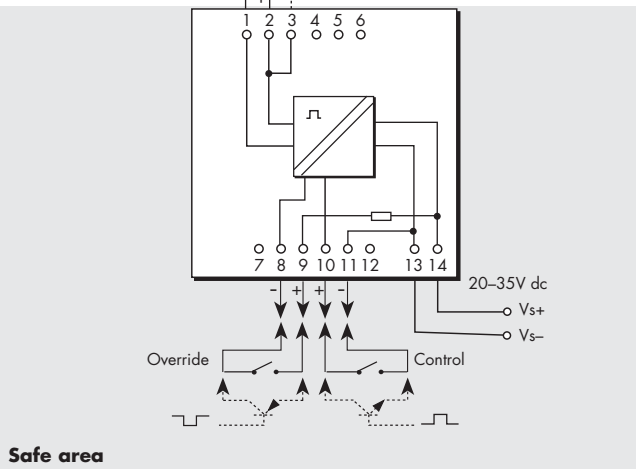
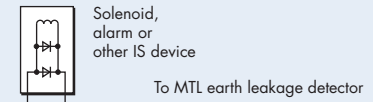

Terminal	Function
1	Output -ve
2	Output +ve
3	To earth leakage detector*
8	Override -ve
9	Override +ve
10	Control +ve
11	Control -ve
13	Supply -ve
14	Supply +ve

*Signal plug HAZ1-3 is required for access to this function

LED indicators

Green: power indication

Yellow: output status, on when output circuit is active

Maximum current consumption

100mA at 24V dc

Power dissipation within unit

1.3W with typical solenoid valve, output on

1.9W worst case

Safety description

$V_o = 25V$ $I_o = 83.3mA$ $P_o = 521mW$ $U_m = 253V$ rms or dc



MTL4541 REPEATER POWER SUPPLY

4/20mA, smart, for 2- or 3-wire transmitters

The MTL4541 provides a fully-floating dc supply for energising a conventional 2- or 3-wire 4/20mA transmitter which is located in a hazardous area, and repeats the current in another floating circuit to drive a safe-area load. For smart 2-wire transmitters, the unit allows bi-directional communications signals superimposed on the 4/20mA signal.

SPECIFICATION

See also common specification

Number of channels

One

Location of transmitter

Zone 0, IIC, T4-6 hazardous area if suitably certified
Div. 1, Group A hazardous location

Safe-area output

Signal range: 4 to 20mA
Under/over-range: 0 to 24mA
Safe-area load resistance: 0 to 360Ω @ 24mA
0 to 450Ω @ 20mA
Safe-area circuit output resistance: > 1MΩ

Safe-area circuit ripple

< 50μA peak-to-peak

Hazardous-area input

Signal range: 0 to 24mA (including over-range)
Transmitter voltage: 16.5V at 20mA

Transfer accuracy at 20°C

Better than 15μA

Temperature drift

< 0.8μA/°C

Response time

Settles to within 10% of final value within 50μs

Communications supported

HART® (terminals 1 & 2 only)

LED indicator

Green: power indication

Maximum current consumption (with 20mA signal)

51mA at 24V

Power dissipation within unit (with 20mA signal)

0.7W at 24V

Safety description

Terminals 2 to 1 and 3:

$V_o=28V$ $I_o=93mA$ $P_o=651mW$ $U_m = 253V$ rms or dc

Terminals 1 to 3:

Simple apparatus ≤1.5V, ≤0.1A and ≤25mW; can be connected without further certification into any IS loop with an open-circuit voltage <28V

Hazardous area

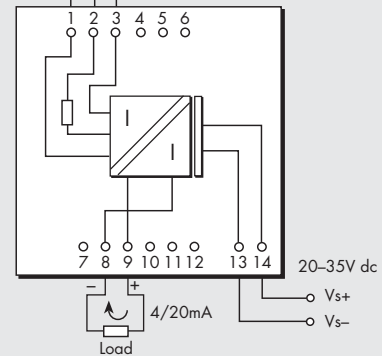
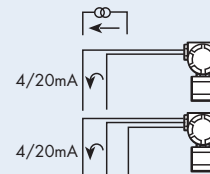

Safe area

Terminal	Function
1	Current input
2	Transmitter supply +ve
3	Common
8	Output -ve
9	Output +ve
13	Supply -ve
14	Supply +ve

MTL4541B REPEATER POWER SUPPLY

4/20mA, smart, for 2- or 3-wire transmitters

The MTL4541B provides a fully-floating dc supply for energising a conventional 2- or 3-wire 4/20mA transmitter which is located in a hazardous area, and repeats the current in another circuit to drive a safe-area load. For smart 2-wire transmitters, the unit allows bi-directional communications signals superimposed on the 4/20mA signal.

SPECIFICATION

See also common specification

Number of channels

One

Location of transmitter

Zone 0, IIC, T4-6 hazardous area if suitably certified
Div. 1, Group A hazardous location

Safe-area output

Signal range: 4 to 20mA
Under/over-range: 0 to 24mA
Safe-area load resistance: 0 to 360Ω @ 24mA
0 to 450Ω @ 20mA
Safe-area circuit output resistance: > 1MΩ

Safe-area circuit ripple

<50μA peak-to-peak

Hazardous-area input

Signal range: 0 to 24mA (including over-range)
Transmitter voltage: 16.5V at 20mA

Transfer accuracy at 20°C

Better than 15μA

Temperature drift

< 0.8μA/°C

Response time

Settles to within 10% of final value within 50μs

Communications supported

HART® (terminals 1 & 2 only)

LED indicator

Green: power indication

Maximum current consumption (with 20mA signal)

51mA at 24V

Power dissipation within unit (with 20mA signal)

0.7W at 24V

Safety description

Terminals 2 to 1 and 3:

$V_o=28V$ $I_o=93mA$ $P_o=651mW$ $U_m = 253V$ rms or dc

Terminals 1 to 3:

Simple apparatus ≤1.5V, ≤0.1A and ≤25mW; can be connected without further certification into any IS loop with an open-circuit voltage <28V

Hazardous area

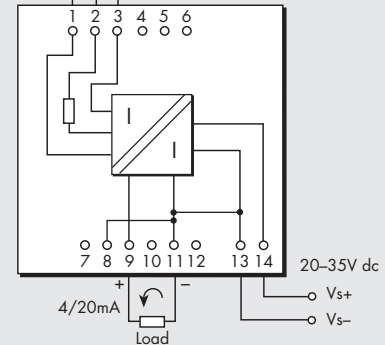
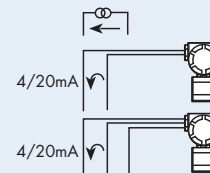

Safe area

Terminal	Function
1	Current input
2	Transmitter supply +ve
3	Common
8	Output -ve
9	Output +ve
11	Output -ve
13	Supply -ve
14	Supply +ve

Note: Safe area output referenced to PSU -ve



MTL4541P REPEATER POWER SUPPLY

4/20mA, smart, for 2- or 3-wire transmitters

The MTL4541P provides a fully-floating dc supply for energising a conventional 2- or 3-wire 4/20mA transmitter which is located in a hazardous area, and repeats the current in another circuit to drive a safe-area load. For smart 2-wire transmitters, the unit allows bi-directional communications signals superimposed on the 4/20mA signal.

The MTL4541P is a higher power version of the MTL4541B, usable for all gas groups provided that the field equipment is suitably certified.

SPECIFICATION

See also common specification

Number of channels

One

Location of transmitter

Zone 0, IIC, T4–6 hazardous area if suitably certified
Div. 1, Group A hazardous location

Safe-area output

Signal range: 4 to 20mA
Under/over-range: 0 to 24mA
Safe-area load resistance: 0 to 360Ω @ 24mA
0 to 450Ω @ 20mA
Safe-area circuit output resistance: > 1MΩ

Safe-area circuit ripple

<50μA peak-to-peak

Hazardous-area input

Signal range: 0 to 24mA (including over-range)
Transmitter voltage: 17.6V at 20mA

Transfer accuracy at 20°C

Better than 15μA

Temperature drift

< 0.8μA/°C

Response time

Settles to within 10% of final value within 50μs

Communications supported

HART® (terminals 1 & 2 only)

LED indicator

Green: power indication

Maximum current consumption (with 20mA signal)

51mA at 24V

Power dissipation within unit (with 20mA signal)

0.7W at 24V

Safety description

Terminals 2 to 1 and 3:

$V_o=28V$ $I_o=116.6mA$ $P_o=820mW$ $U_m=253V$ rms or dc

Terminals 1 to 3:

Simple apparatus $\leq 1.5V$, $\leq 0.1A$ and $\leq 25mW$; can be connected without further certification into any IS loop with an open-circuit voltage <28V

Hazardous area

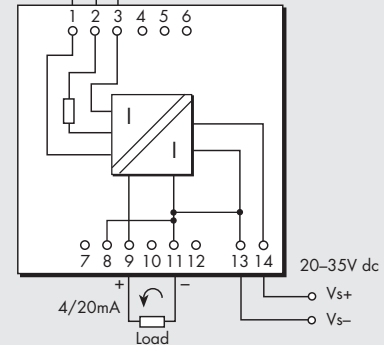
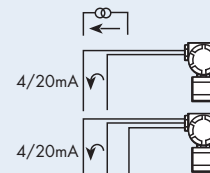

Safe area

Terminal	Function
1	Current input
2	Transmitter supply +ve
3	Common
8	Output -ve
9	Output +ve
11	Output -ve
13	Supply -ve
14	Supply +ve

Note: Safe area output referenced to PSU -ve



EUROPE (EMEA)
AMERICAS
ASIA PACIFIC
E-mail: enquiry@mtl-inst.com

Tel: +44 (0)1582 723633
Tel: +1 281 571 8065
Tel: +65 6 487 7887

Fax: +44 (0)1582 422283
Fax: +1 281 571 8069
Fax: +65 6 487 7997
Web site: www.mtl-inst.com

MTL4544 REPEATER POWER SUPPLY

two channel, 4/20mA, smart,
for 2- or 3- wire transmitters

The MTL4544 provides fully-floating dc supplies for energising two conventional 2-wire or 3-wire 4/20mA or 'smart' transmitters located in a hazardous area, and repeats the current in other circuits to drive two safe-area loads. For smart transmitters, the unit allows bi-directional transmission of digital communication signals superimposed on the 4/20mA signal so that the transmitter can be interrogated either from the operator station or by a hand-held communicator.

SPECIFICATION

See also common specification

Number of channels

Two

Location of transmitter

Zone 0, IIC, T4-6 hazardous area if suitably certified
Div. 1, Group A hazardous location

Safe-area output

Signal range: 4 to 20mA
Under/over-range: 0 to 24mA
Safe-area load resistance: 0 to 360Ω @ 24mA
0 to 450Ω @ 20mA
Safe-area circuit output resistance: > 1MΩ

Safe-area circuit ripple

< 50µA peak-to-peak

Hazardous-area input

Signal range: 0 to 24mA (including over-range)
Transmitter voltage: 16.5V at 20mA

Transfer accuracy at 20°C

Better than 15µA

Temperature drift

< 0.8µA/°C

Response time

Settles to within 10% of final value within 50µs

Communications supported

HART® (terminals 1 & 2 and 4 & 5 only)

LED indicator

Green: power indication

Maximum current consumption (with 20mA signals)

96mA at 24V dc

Power dissipation within unit (with 20mA signals)

1.4W at 24V dc

Safety description (each channel)

Terminals 2 to 1 and 3, and 5 to 4 and 6:

$V_o=28V$ $I_o=93mA$ $P_o=651mW$ $U_m=253V$ rms or dc

Terminals 1 to 3 and 4 to 6:

Simple apparatus $\leq 1.5V$, $\leq 0.1A$ and $\leq 25mW$; can be connected without further certification into any IS loop with an open-circuit voltage <28V

Hazardous area

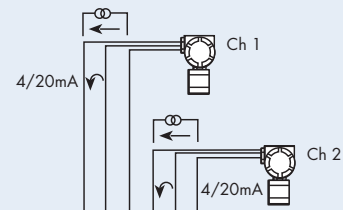

Safe area

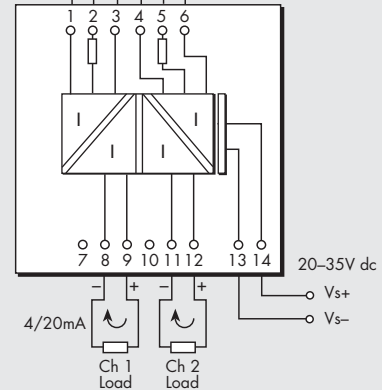

Terminal	Function
1	Ch1 current input
2	Ch1 transmitter supply +ve
3	Ch1 common
4	Ch2 current input
5	Ch2 transmitter supply +ve
6	Ch2 common
8	Ch1 output -ve
9	Ch1 output +ve
11	Ch2 output -ve
12	Ch2 output +ve
13	Supply -ve
14	Supply +ve

Hazardous area

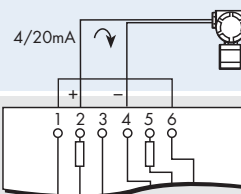

Safe area

The MTL4544 can also be used to drive two safe-area loads from a single 2-wire transmitter (i.e. 1 in, 2 out) by interconnecting the input channels as shown in the diagram here.

Note: In this mode the HART data is transferred via channel 1 output only.



MTL4544B REPEATER POWER SUPPLY

two channel, 4/20mA, smart,
for 2-wire or 3-wire transmitters

The MTL4544B provides fully-floating dc supplies for energising two conventional 2-wire or 3-wire 4/20mA or 'smart' transmitters located in a hazardous area, and repeats the current in other circuits to drive two safe-area loads. For smart transmitters, the unit allows bi-directional transmission of digital communication signals superimposed on the 4/20mA signal so that the transmitter can be interrogated either from the operator station or by a hand-held communicator.

SPECIFICATION

See also common specification

Number of channels

Two

Location of transmitter

Zone 0, IIC, T4-6, hazardous area if suitably certified
Div 1, Group A, hazardous location

Safe-area output

Signal range: 4 to 20mA
Under/over-range: 0 to 24mA
Safe-area load resistance: 0 to 360Ω @ 24mA
0 to 450Ω @ 20mA
Safe-area circuit output resistance: > 1MΩ

Safe-area circuit ripple

< 50µA peak-to-peak

Hazardous-area input

Signal range: 0 to 24mA (including over-range)
Transmitter voltage: 16.5V at 20mA

Transfer accuracy at 20°C

Better than 20µA

Temperature drift

< 0.8µA/°C

Response time

Settles to within 10% of final value within 50µs

Communications supported

HART® (terminals 1 & 2 and 4 & 5 only)

LED indicator

Green: power indication

Maximum current consumption (with 20mA signals)

96mA at 24V dc

Power dissipation within unit (with 20mA signals)

1.4W at 24V dc

Safety description (each channel)

Terminals 2 to 1 and 3, and 5 to 4 and 6:

$V_o=28V$ $I_o=93mA$ $P_o=651mW$ $U_m=253V$ rms or dc

Terminals 1 to 3 and 4 to 6:

Simple apparatus $\leq 1.5V$, $\leq 0.1A$ and $\leq 25mW$; can be connected without further certification into any IS loop with an open-circuit voltage <28V

Hazardous area

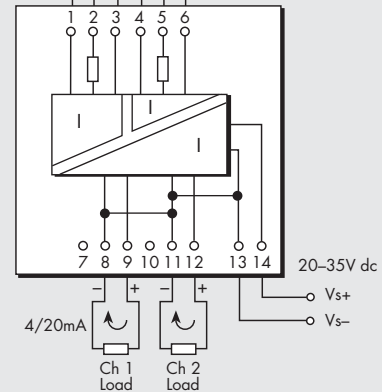
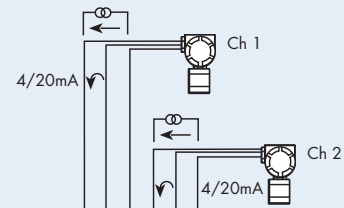

Safe area

Terminal	Function
1	Ch1 current input
2	Ch1 transmitter supply +ve
3	Ch1 common
4	Ch2 current input
5	Ch2 transmitter supply +ve
6	Ch2 common
8	Ch1 output -ve
9	Ch1 output +ve
11	Ch2 output -ve
12	Ch2 output +ve
13	Supply -ve
14	Supply +ve

Note: Safe area output referenced to PSU -ve



MTL4546/4546C

ISOLATING DRIVER

for 4–20mA smart valve positioners
with line fault detection

The MTL4546 accepts a 4/20mA floating signal from a safe-area controller to drive a current/pressure converter (or any other load up to 800Ω) in a hazardous area. For smart valve positioners, the module also permits bi-directional transmission of digital communication signals so that the device can be interrogated either from the operator station or by a hand-held communicator. Process controllers with a readback facility can detect open or short circuits in the field wiring: if these occur, the current taken into the terminals drops to a preset level. The MTL4546C is identical to the MTL4546 except that it provides open circuit detection only (no short-circuit detection).

SPECIFICATION

See also common specification

Number of channels

One

Location of I/P converter

Zone 0, IIC, T4–6 hazardous area if suitably certified
Div. 1, Group A, hazardous location

Working range

4 to 20mA

Digital signal bandwidth

500Hz to 10kHz

Maximum load resistance

800Ω (16V at 20mA)

Minimum load resistance

90Ω (short-circuit detection at < 50Ω)

Output resistance

> 1MΩ

Under/over range capability

Under range = 1mA
Over range = 24mA (load ≤ 520Ω)

Input and output circuit ripple

< 40μA peak-to-peak

Transfer accuracy at 20°C

Better than 20μA

Temperature drift

< 1.0μA/°C

Input characteristics

< 6.0V with the field wiring intact
< 0.9mA with the field wiring open-circuit (and short-circuit on the MTL4546)

Response time

Settles within 200μA of final value within 100ms

Communications supported

HART®

LED indicator

Green: power indication

Maximum current consumption (with 20mA signal)

35mA at 24V dc

Power dissipation within unit (with 20mA signal)

0.8W at 24V

Safety description

$V_o=28V$ $I_o=93mA$ $P_o=651mW$ $U_m = 253V$ rms or dc

Hazardous area

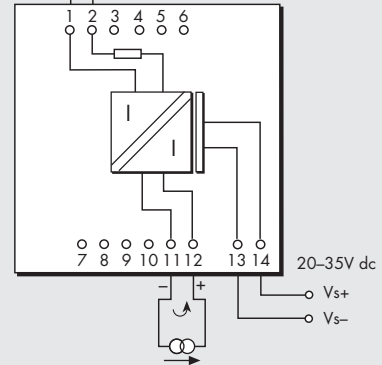
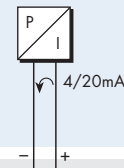

Safe area

Terminal	Function
1	Output -ve
2	Output +ve
11	Input -ve
12	Input +ve
13	Supply -ve
14	Supply +ve



MTL4549/4549C

ISOLATING DRIVER

two-channel, for 4–20mA smart valve positioners with line fault detection

The MTL4549 accepts 4/20mA floating signals from safe-area controllers to drive 2 current/pressure converters (or any other load up to 800Ω) in a hazardous area. For smart valve positioners, the module also permits bi-directional transmission of digital communication signals so that the device can be interrogated either from the operator station or by a hand-held communicator. Process controllers with a readback facility can detect open or short circuits in the field wiring; if these occur, the current taken into the terminals drops to a preset level. The MTL4549C is identical to the MTL4549 except that it provides open circuit detection only (no short-circuit detection).

SPECIFICATION

See also common specification

Number of channels

Two

Location of I/P converter

Zone 0, IIC, T4–6 hazardous area if suitably certified
Div. 1, Group A, hazardous location

Working range

4 to 20mA

Digital signal bandwidth

500Hz to 10kHz

Maximum load resistance

800Ω (16V at 20mA)

Minimum load resistance

90Ω (short-circuit detection at < 50Ω)

Output resistance

> 1MΩ

Under/over range capability

Under range = 1mA
Over range = 24mA (load ≤ 520Ω)

Input and output circuit ripple

< 40μA peak-to-peak

Transfer accuracy at 20°C

Better than 20μA

Temperature drift

< 1.0μA/°C

Input characteristics

< 6.0V with the field wiring intact
< 0.9mA with the field wiring open-circuit (and short-circuit on the MTL4549)

Response time

Settles within 200μA of final value within 100ms

Communications supported

HART®

LED indicator

Green: power indication

Maximum current consumption (with 20mA signals)

70mA at 24V dc

Power dissipation within unit (with 20mA signals)

1.6W at 24V

Safety description (each channel)

$V_o=28V$ $I_o=93mA$ $P_o=651mW$ $U_m = 253V$ rms or dc

Hazardous area

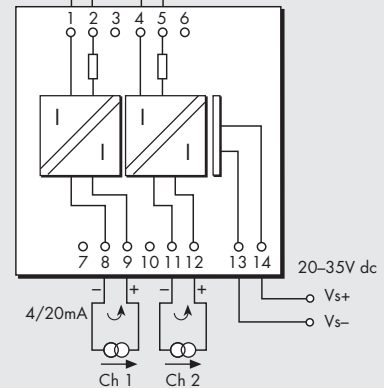
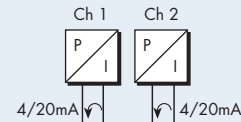

Safe area

Terminal	Function
1	Output -ve (Ch 1)
2	Output +ve (Ch 1)
4	Output -ve (Ch 2)
5	Output +ve (Ch 2)
8	Input -ve (Ch 1)
9	Input +ve (Ch 1)
11	Input -ve (Ch 2)
12	Input +ve (Ch 2)
13	Supply -ve
14	Supply +ve



MTL4575

TEMPERATURE CONVERTER

THC or RTD input + Alarm

The MTL4575 converts a low-level dc signal from a temperature sensor mounted in a hazardous area into a 4/20mA current for driving a safe-area load. Software selectable features include linearisation, ranging, monitoring, testing and tagging for all thermocouple types and 2-, 3- or 4-wire RTDs. (For thermocouple applications the HAZ-CJC plug on terminals 1–3 includes an integral CJC sensor). Configuration is carried out using a personal computer. A single alarm output is provided and may be configured for high or low process alarm or to provide notice of early thermocouple failure.

SPECIFICATION

See also common specification

Number of channels

One

Signal source

Types J, K, T, E, R, S, B or N THCs to BS 60584 and XK
EMF input
Pt 100, Pt 500, Pt 1000
2/3/4-wire platinum RTDs to BS 60751
Cu-50 & Cu-53
Ni 100/500/1000 DIN 43760

Location of signal source

Zone 0, IIC, T4-6 hazardous area
Division 1, Group A, hazardous location

Input signal range

-75 to +75mV, or 0 to 400Ω (0 to 1000Ω Pt & Ni sensors)

Input signal span

3 to 150mV, or 10 to 400Ω (10 to 1000Ω Pt & Ni sensors)

RTD excitation current

200μA nominal

Cold junction compensation

Automatic or selectable

Cold junction compensation error

≤ 1.0°C

Common mode rejection

120dB for 240V at 50Hz or 60Hz (500ms response)

Series mode rejection

40dB for 50Hz or 60Hz

Calibration accuracy (at 20°C)

(includes hysteresis, non-linearity and repeatability)

Inputs: (500ms response)

mV/THC: ± 15μV or ± 0.05% of input value (whichever is greater)

RTD: ± 80mΩ

Output: ± 11μA

Temperature drift (typical)

Inputs:

mV/THC: ± 0.003% of input value/°C

RTD: ± 7mΩ/°C

Output: ± 0.6μA/°C

Example of calibration accuracy and temperature drift (RTD input - 500ms response)

Span: 250Ω

Accuracy: ± (0.08/250 + 11/16000) x 100% = 0.1% of span

Temperature drift: ± (0.007/250 x 16000 + 0.6) μA/°C = ± 1.0μA/°C

Hazardous area

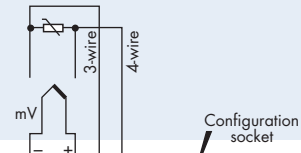

Safe area

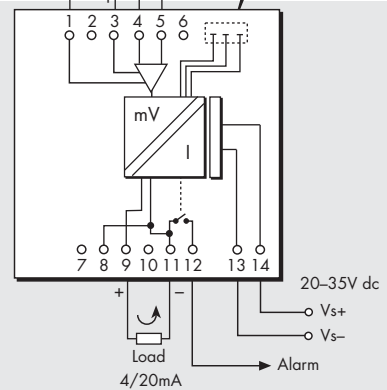

Terminal	Function
1	THC/EMF/RTD input -ve
3	THC/EMF/RTD input +ve
4	3-wire RTD input -ve
5	4-wire RTD input +ve
8	Output -ve
9	Output +ve
11	Output -ve/Alarm relay
12	Alarm relay
13	Supply -ve
14	Supply +ve

Safety drive on sensor burnout

Upscale, downscale, or off

Early burnout

Early burnout detection for thermocouples (when selected)
Alarm trips when loop resistance increase is > 50Ω

Output range

4 to 20mA nominal into 600Ω max. (direct or reverse)

Alarm output

Relay ON in alarm, 250mA @ 35V max

Maximum lead resistance (THC)

600Ω

Response time

Configurable - 500 ms default
(Accuracy at 100/200ms - contact MTL)

LED indicator

Green: power and status indication
Yellow: alarm indication, on when contacts are closed

Maximum current consumption (with 20mA signal)

50mA at 24V

Power dissipation within unit (with 20mA signal)

1.2W at 24V

Safety description

Refer to certificate for entity parameters. Um=253V rms or dc.s

Configurator

A personal computer running MTL PCS45 software with a PCL45USB serial interface.



MTL4599 DUMMY ISOLATOR

The primary function of the MTL4599, which can be used with all other MTL4500 Series units, is to provide termination and earthing facilities for unused cable cores from hazardous areas.

SPECIFICATION

See also common specification

Weight
60g

Hazardous area

Unused field cores

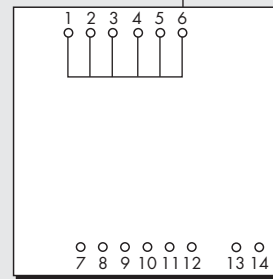

Safe area

MTL4599N GENERAL PURPOSE FEED-THROUGH MODULE

The feed-through termination module allows non-IS connections to the MTL4500 backplanes. The wires from the field are connected using screw terminals. Six terminals are provided for each contact of the multiway connector on the backplane. The terminals and cables conform to IS regulations so that non-IS and IS signals can be mixed on the same backplane.

Note: Must not be used with signals >50V or >0.25A

SPECIFICATION

See also common specification

Weight
60g

Safe area

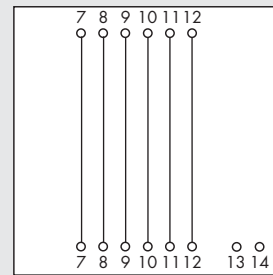

MTL4500 SERIES COMMON SPECIFICATION

Please go to our website at www.mtl-inst.com for the latest information regarding safety approvals, certificates and entity parameters.

Connectors

Each MTL4500 unit is supplied with signal connectors, as applicable.

When using crimp ferrules for the hazardous and non-hazardous (safe) signal connectors the metal tube length should be 12mm and the wire trim length 14mm.

Isolation

250V rms, tested at 1500V rms minimum, between safe- and hazardous-area terminals.

50V between safe-area circuits and power supply

Supply voltage

20 – 35V dc

Location of units

Safe area

Terminals

Accepts conductors of up to 2.5mm² stranded or single-core

Mounting

MTL4500 series backplanes

Ambient temperature limits

-20 to +60°C (-6 to +140°F) operating

-40 to +80°C (-40 to +176°F) storage

Humidity

5 to 95% relative humidity

Weight

110g approximately (except where indicated)

DIMENSIONS (mm)

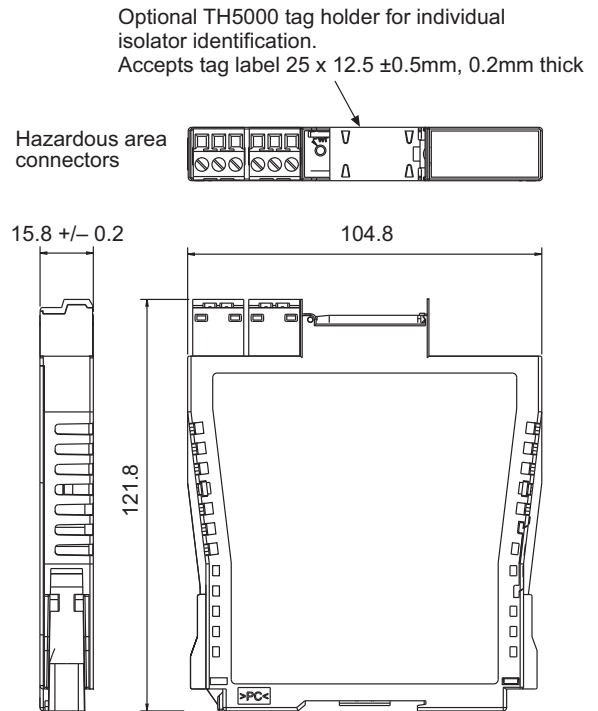

HART® is a registered trademark of HART Communication Foundation



EUROPE (EMEA)

Tel: +44 (0)1582 723633

Fax: +44 (0)1582 422283

AMERICAS

Tel: +1 281 571 8065

Fax: +1 281 571 8069

ASIA PACIFIC

Tel: +65 6 487 7887

Fax: +65 6 487 7997

E-mail: enquiry@mtl-inst.com Web site: www.mtl-inst.com

CUSTOM, STANDARD AND UNIVERSAL BACKPLANES FOR EASY DCS INTEGRATION

- ◆ Total flexibility
- ◆ Reduce wiring
- ◆ Simplify installation
- ◆ Special functions
- ◆ Signal conditioning
- ◆ HART® integration

The MTL4500 Series backplanes, enclosures and other accessories provide comprehensive, flexible and remarkably compact mounting facilities for system vendors, original equipment manufacturers and end users alike.

CUSTOMISED BACKPLANES

MTL provides a complete design and manufacturing service for customised backplanes. Customised backplanes give the vendors and users of process control and safety systems the opportunity to integrate MTL4500/HART® modules directly into their system architecture. As there are no hazardous-area circuits on the backplanes, customised versions can be produced without the need for IS certification, so simplifying design and lowering costs.

UNIVERSAL CUSTOM BACKPLANES

The 'universal' backplane allows a fast and economic approach to providing a custom interface. Where tight time schedules exist, the backplane can be installed to allow the panel building and wiring to be completed. The customised adapter card can then be plugged in at any time up to integrated test.

ADAPTER CARDS

Adapter cards already exist for many of the DCS companies. In addition there is a range of general purpose cards that offer reduced wiring for use with specific MTL modules. These are also available in left- and right-hand versions to ease panel wiring.

STANDARD MTL BACKPLANES

Standard MTL backplanes are available to accommodate 4, 8, 16, or 24 modules using screw-clamp connectors for the safe-area circuits. On an individual backplane, any module can be plugged into any position and module types can be mixed. For 8-, 16- and 24-way backplanes, screw-clamp connectors which plug into the backplanes provide primary and secondary 24V dc power supplies. Power to several 8- or 16-way backplanes can be interconnected to reduce and simplify wiring – see instruction manual INM4500 for details.



OPTIONAL ACCESSORIES

Optional accessories include colour coded tagging strip kits for all three sizes of backplane and earth rail kits for 8 and 16-way versions. Mounting accessories are available for surface (all backplanes), T-section and G-section DIN-rail (8- and 16-way versions), and a horizontal plate for mounting 24-way backplanes in 19-inch racks.

WEATHERPROOF ENCLOSURES

Weatherproof enclosures are available for applications where separate safe-area enclosures are required for backplanes with modules. Available to accommodate one 4-way or one 8-way backplane, they are manufactured from GRP giving protection against dust and water to IEC529:IP65. The lids are made from transparent high-strength polycarbonate so that LEDs, switches, etc, on the tops of the modules

DCS VENDORS/SYSTEMS SUPPORTED:

ABB Automation

S100
INFI90

Rockwell Automation

Bently-Nevada

Foxboro

IA FBM & FBM2xx

Siemens-Moore

APACS
Quadlog

Honeywell

TDC
Plantscape

Honeywell-SMS

FSC

ICS

Triplex
Plantguard

Triconex

Tricon
Trident

Yokogawa

Centum XL, µXL
CS1000, CS3000, R3

Yokogawa Industrial Safety Systems

ProSafe & ProSafe RS



EUROPE (EMEA)

Tel: +44 (0)1582 723633

Fax: +44 (0)1582 422283

AMERICAS

Tel: +1 281 571 8065

Fax: +1 281 571 8069

ASIA PACIFIC

Tel: +65 6 487 7887

Fax: +65 6 487 7997

E-mail: enquiry@mtl-inst.com Web site: www.mtl-inst.com

MTL CPS STANDARD BACKPLANES - FEATURES

Backplane model no.	Number of modules	Safe-area connections	MOUNTING KITS			ACCESSORIES		
			Surface	DIN-rail (T or G)	19-inch rack	Earth-rail kit	Tagging strip kit	Spare fuse pack
CPS04	4	Screw-clamp	SMS01	DMK01	–	–		FUS1.0ATE5
CPS08	8	Screw-clamp	SMS01	DMK01	–	ERK08	TSK08	FUS1.0ATE5
CPS16	16	Screw-clamp	SMS01	DMK01	–	ERK16	TSK16	FUS2.0ATE5
CPS24	24	Screw-clamp	SMS01	DMK01	HMP24	–	TSK24	FUS2.0ATE5

SPECIFICATION

Power requirements, Vs

21V dc to 35V dc through plug-in connectors

Safe-area connections

CPS: 2.5mm² screw-clamp terminals – 6 positions per module

Power sense

Through separate plug-in crimp connector

Weight (without modules or accessories)

CPS04:	96g
CPS08:	225g
CPS16:	419g
CPS24:	592g

CPS BACKPLANES DIMENSIONS (mm)

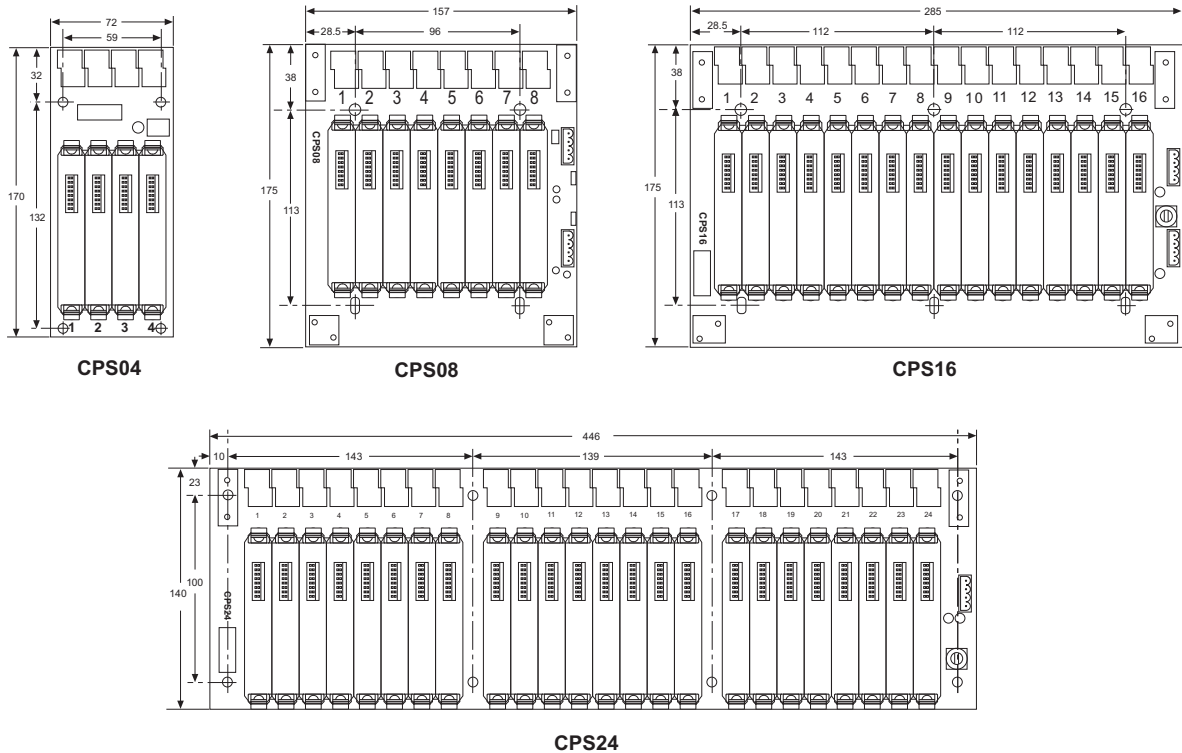

MTL4500 MODULE AND BACKPLANE ACCESSORIES

- HAZ1-3** Hazardous-area plug, terminals 1, 2 and 3
- HAZ4-6** Hazardous-area plug, terminals 4, 5 and 6
- HAZ-CJC** Hazardous-area plug, terminals 1 and 3 with cold junction sensor
- SAF1-3** Safe-area plug, terminals 1, 2 and 3
- SAF4-6** Safe-area plug, terminals 4, 5 and 6
- ERK08** Earth rail kit for CPS08 backplanes
- ERK16** Earth rail kit for CPS16 backplanes
- TSK08** Tagging strip kit for CPS08 backplanes
- TSK16** Tagging strip kit for CPS16 backplanes
- TSK24** Tagging strip kit for CPS24 backplanes
- SMS01** Backplane surface mounting kit, pack of 40
- DMK01** Backplane DIN-rail mounting kit, G- or T-section, pack of 40
- BMK08** Mounting kit – surface/DIN-rail accessories for one 4- or 8-way backplane
- BMK16** Mounting kit – surface/DIN-rail accessories for one 16-way backplane
- HMP24** Horizontal mounting plate and screws for 19-inch rack, 24-way backplane only
- FUS1.0ATE5** Fuse kit, CPS04,08 backplanes, pack of 10
- FUS2.0ATE5** Fuse kit, CPS16 backplanes, pack of 10
- FUS4.0ATE5** Fuse kit, CPS24 backplanes, pack of 10
- MPL01** Module position labels (blank), pack of 50
- MCK45** Module conversion kit for MTL4000 backplanes, pack of 16 pairs of clips.

MTL BX08 ENCLOSURE

SPECIFICATIONS

BX08: for 1 x CPS04 or CPS08 backplane

Location

Safe area

Protection

Dust-tight and water-jet proof to IEC529:IP65

Ambient temperature limits

-20°C to +60°C, depending upon modules fitted (see instruction manual INM4500 for details)

Construction

Base: GRP (glass-fibre reinforced polyester)
Lid: transparent high-strength polycarbonate

Finish

Base: light grey
Lid: transparent

Lid fixing

Captive fixing screws

Gland fixing

Side mounted gland plate, detachable for drilling by user

Mounting

By exterior surface-fixing lugs (zinc-passivated steel)

Backplane accessories

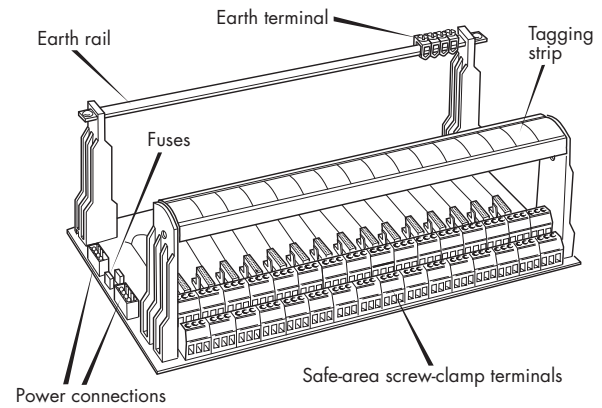

HMP24 mounting plate for 19 inch rack

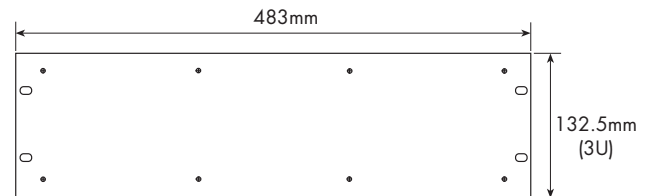

Dimensions

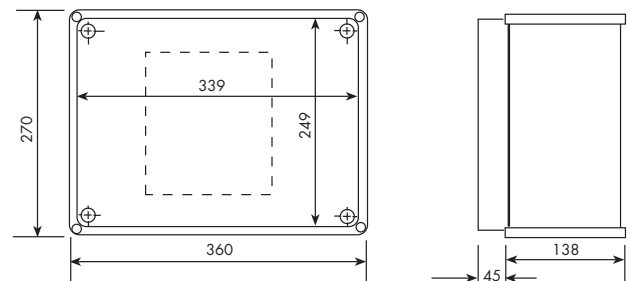

Internal cable trunking

Provided on all enclosures

Backplane mounts

Necessary surface mounting kits (of screws, washers, spacers and retaining washers) are provided with the enclosure

Weight (without backplanes and units)

3.7kg



MTL4500 SERIES ORDERING INFORMATION



Intrinsically-safe interface units

Specify module number

Module accessories

HAZ1-3*	Hazardous-area plug, terminals 1, 2 and 3
HAZ4-6*	Hazardous-area plug, terminals 4, 5 and 6
HAZ-CJC*	Hazardous-area plug, terminals 1 and 3 with cold-junction sensor
SAF1-3	Safe-area plug, terminals 1, 2 and 3
SAF4-6	Safe-area plug, terminals 4, 5 and 6
TH5000	Tag holder (20 per pack)

* These items are supplied with the interface module and are also available as spares

Configurator (MTL4575)

PCL45USB	Configurator, PC software and interface
PCS45	Configurator software (Free download: www.mtl-inst.com)



Backplane accessories

ERK08	Earth rail kit for CPS08 backplane
ERK16	Earth rail kit for CPS16 backplane
TSK08	Tagging strip kit for CPS08 backplane
TSK16	Tagging strip kit for CPS16 backplane
TSK24	Tagging strip kit for CPS24 backplane
FUS1.0ATE5	Fuse kit for 4- and 8-way backplanes, (10 per pack)
FUS2.0ATE5	Fuse kit for 16-way backplane, (10 per pack)
FUS4.0ATE5	Fuse kit for 24-way backplanes, (10 per pack)
MCK45	MTL4000 backplane conversion kit (16 clip pairs per pack)
MPL01	Module position label (blank) (50 per pack)



Backplanes

CPS04	4-way backplane screw-clamp connector
CPS08	8-way backplane screw-clamp connector
CPS16	16-way backplane screw-clamp connector
CPS24	24-way backplane screw-clamp connector

Backplane mounting accessories

DMK01	DIN-rail mounting kit, T- or G-section (pack of 40) 8-way backplanes require 4, 16-way backplanes require 6
SMS01	Surface mounting kit (pack of 40) 4- and 8-way backplanes require 4, 16-way backplanes require 6, 24-way backplanes require 8
HMP24	Horizontal mounting plate and screws for 19-inch rack mounting 24-way backplanes only
BMK08	Mounting kit for one 4- or 8-way backplane
BMK16	Mounting kit for one 16-way backplane



Enclosures

BX08	8-way enclosure, suitable for 1 CPS04 or CPS08
------	--



Literature

INM4500	MTL4500 Series instruction manual
---------	-----------------------------------

